

Sculptural pieces for sophisticated interiors

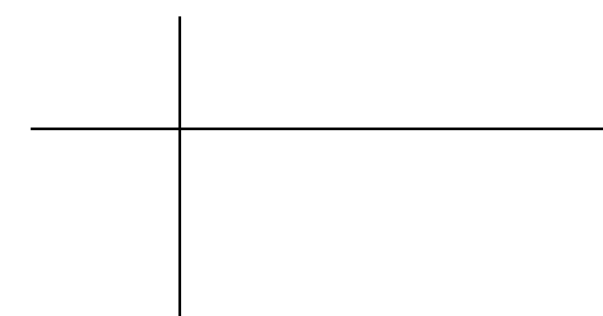

CHAIRS & STOOLS

- 58 BOLT
- 59 TEMBO
- 60 RONIN
- 61 PLANET

SOFAS & ARMCHAIRS

- 62 BORGHESE
- 64 BLOCK
- 65 X RAY

BED

- 68 SUNDAY

TABLES & DESKS

- 69 MEWOMA
- 72 SUNDAY

COFFEE TABLES & OCCASIONAL

- 73 SUNDAY
- 74 SALUTE
- 77 FLOAT
- 78 BORGHESE
- 79 ZORRO

SHELVING & STORAGE

- 80 CLIMB
- 82 BUMP
- 83 ROCKY

LIGHTING

- 85 SORCIER
- 86 TIP TOP
- 87 VULCAIN
- 88 APOLLO
- 89 SWAN
- 90 CYMBAL
- 91 FAX

ACCESSORIES

- 92 ICONIC
- 93 LALOU
- 94 JEEVES
- 95 ZAG
- 96 TOY

RUGS

- 97 ANEMONE
- 98 TAPIGRI
- 99 FRANCE
- 100 ORGIE
- 101 CROSS

WALLPAPERS

- 102 JER
- 103 HAPPY RAIN

————— Tembo, stool, p.59



SCULPTURAL PIECES FOR SOPHISTICATED INTERIORS

La Chance is a Paris based company producing furniture, lighting, accessories, rugs and wallpapers with a strong and distinctive style.

La Chance gives a contemporary interpretation of the ornamental and decorative French furniture tradition rooted in the Art Deco period.

The creations of La Chance share a sophisticated, rich and singular design based on noble materials.

La Chance produces contemporary family furniture and investment pieces for this generation as well as the next generations to enjoy.

Salute low, coffee table,
p.76 | Anemone, rug, p.97

Lalou, table mirror, p.93 |
JER, wallpaper, p.102 | Ronin, chair,
p.60



THE FRENCH HERITAGE

Art Deco is a major aesthetic movement that emerged in France just before World War 1 and dominated the artistic world until the decline of the late 30s. It succeeded the exuberance of Art Nouveau and returned to purer and bolder forms while offering both a geometric and decorative style. Art deco is a major inspiration in La Chance approach to the theatrical approach of interior design and the combined use of materials and textures.

As a designer and decorator, Jacques-Emile Ruhlmann is the leading figure of the movement and established both the aesthetics and theoretic values of Art Deco. Ruhlmann defined himself as an "ensemblier", meaning 'the one who puts together' in French. His interiors reflected this idea and combined his strong personality creations to create a rich but consistent decor for the elite of his time.

La Chance follows this legacy in a modern and creative way :

"As opposed to the Japanese sleek and pure design, or the conceptual Dutch and flamboyant Italian, French furniture is about décor, the idea of décor is central to La Chance".

The brand makes a contemporary transcription of this spirit through re-editions of Jacques-Emile Ruhlmann creations, one of the undisputed masters of this period. His aesthetical and functional pieces remain astonishingly modern, more than 100 years after they were designed by the master.

The accessories collection of La Chance is based on this French Art de vivre : beautiful objects to go through your everyday routine with style.

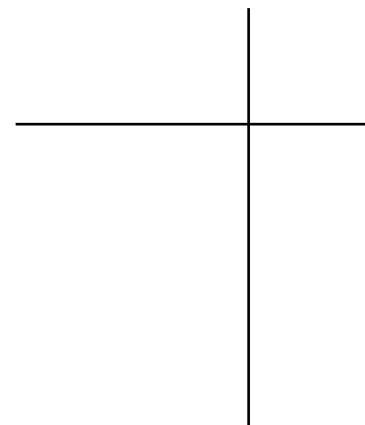

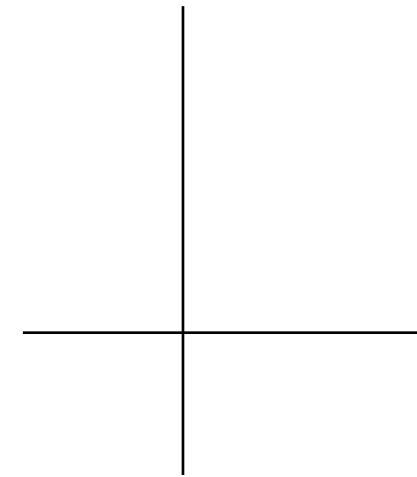

MATERIALS & CRAFTSMANSHIP

“Our love for beautiful materials is guiding the creative approach”. The iconic designs are reinforced by the emphasis on noble and honest materials such as marble, solid wood, metal, cork, leather, blown glass, and pure wool from New Zealand for the rugs.

All La Chance products are made in human scale production units in Europe, except for the rugs that are custom made in India. Over the years, La Chance has developed a strong and respectful relationship with its partners : “Our highly qualified artisans combine traditional techniques and innovative processes to manufacture La Chance products. Each piece passing through the hands of our craftsmen is the object of a particular attention”.

In addition to the main collection, La Chance offers custom products and bespoke services to meet the requirements of each client, both for residential, hotel and commercial projects.

THE DESIGNERS

La Chance produces the works of a cosmopolitan selection of the best designers of the contemporary design scene. Each designer gave his interpretation of the French spirit of La Chance through the prism of his cultural background to create a rich and diverse, albeit consistent, collection.

From the beginning of the adventure, La Chance has been entrusted by the best designers while also still searching for emerging talents and scouting for the most promising profiles worldwide.

La Chance team gathers 26 designers and 14 nationalities.

MARTA BAKOWSKI

GUILLAUME DELVIGNE

NOÉ DUCHAUFOR LAWRENCE

FRANÇOIS DUMAS

MALIKA FAVRE

ALAIN GILLES

SEBASTIAN HERKNER

CHARLES KALPAKIAN

JONAS LUTZ

LUCA NICETTO

NOTE DESIGN STUDIO

NATHALIE DU PASQUIER

JAN PLECHAC & HENRY WIELGUS

POOL

ANATOLE ROYER

JACQUES-EMILE RUHLMANN

JEAN-BAPTISTE SOULETIE

STUDIO BLING

JONAH TAKAGI

TOLILA & GILLILAND

BASHKO TRYBEK

FREDERIK WERNER & EMIL LAGONI VALBAK

DAN YEFFET & LUCIE KOLDOVA

———— Bolt, stool, p.58





THE COLLECTION



Sunday, table, p.72
| Planet, chair, p.61



— Bolt, stool, p.58 |
— Tembo, stool, p.59



— Bump, credenza, p.82



— Mewoma, table, p.69 |
Ronin, chair, p.60 | Swan, pendant
lamp, p.89





— Borghese, sofa, p.62



— Sunday, table, p.72



X Ray, armchair, p.65 | Orgie, rug, p.100 | Bolt, stool, p.58 | Salute, coffee table, p.74 | Borghese, sofa, p.62 | Tapigri, rug, p.98 | Rocky, credenza, p.84 | Vulcain, table lamp, p.87 | Planet, chair, p.61



— Orgie, rug, p.100 |
Borghese, coffee table, p.78



X Ray, daybed, p.67 |
Salute high, coffee table, p.74 | Tip Top,
table lamp, p.86 | Sorcier, wall lamp,
p.85 | X Ray, sofa, p.66

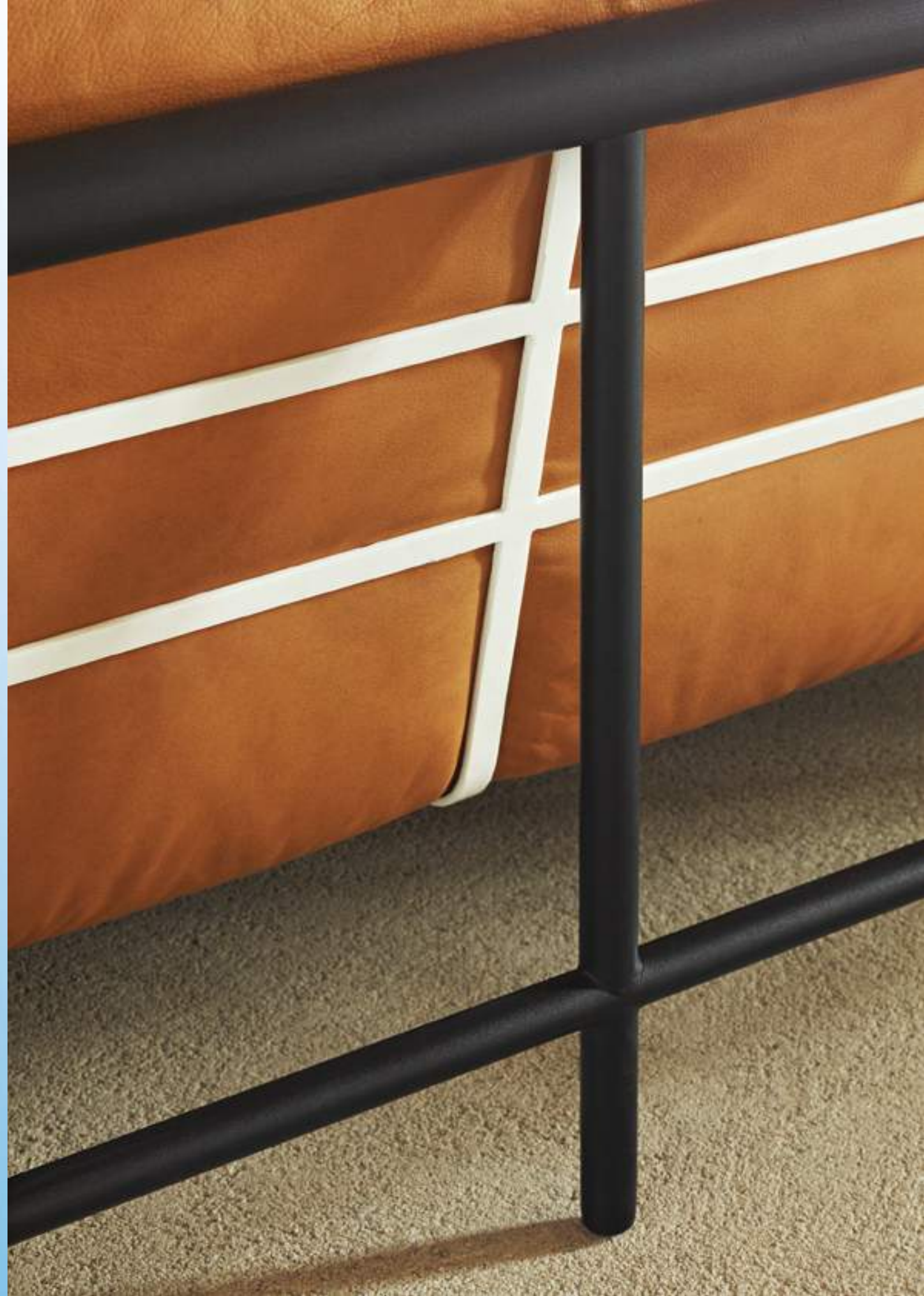



Mewoma
double, table, p.71 |
Ronin, chair, p.60 |
Sorcier, wall lamp, p.85 |
Cymbal, pendant lamp,
p.90



Zag, coat hooks, p.95 |
Jeeves, valet, p.94





Float, coffee table, p.77 | Bump, credenza, p.82 | Apollo, floor lamp, p.88 | X Ray, armchair, p.65 | Toy, vase, p.96 | Iconic, standing mirror, p.92 | Tembo, stool, p.59





Block, armchair, p.64 | Fax, pendant lamp, p.91 | X Ray, sofa, p.66 | Sunday, coffee table, p.73 | Tapigri, rug, p.98







Zorro, coffee table, p.79 | Bolt, stool, p.58 | Tapiгри, rug, p.98





— Fax, pendant lamp, p.91



Salute high, coffee table,
p.74 | Apollo, floor lamp, p.88

Rocky, credenza, p.84 |
Cymbal, pendant lamp, p.90



— Climb, shelving system, p.80 | Sunday, desk, p.72 |
Planet, chair, p.61 | Tip Top, table lamp, p.86 | France, rug, p.99
| Climb, shelving system, p.80 | Borghese, sofa, p.62 | Float,
coffee table, p.77 | Cymbal, pendant lamp, p.90.





———— Cymbal, pendant lamp,
p.90 | Cross, rug, p.101 | Ronin,
chair, p.60

Each project is different.

This is why La Chance offers custom services to go beyond the main collection and create the perfect products for the perfect projects.



CUSTOM PROGRAM

La Chance products are available in a wide variety of materials, colors, dimensions and finishes to adapt to each personality. However sometimes this is not enough. This is why La Chance custom program allows architects, interior designers, and demanding design enthusiasts to adapt our pieces to your needs. Whether you want a larger version, change the colors, use an exotic stone, or upholster your favorite piece in a precise fabric, La Chance creative team is at your disposal to discuss your ideas and help you create your own unique version of La Chance icons.

BESPOKE

La Chance also develops bespoke products for professionals in collaboration with our European network of artisans to create exclusive pieces for high end interiors, hospitality and collectors. La Chance masters a large array of traditional technics and materials, and will help you develop and build the perfect piece from scratch.

INTERIOR DESIGN

La Chance provides interior design services for private and hospitality projects. The design team expands the signature style of La Chance beyond the furniture to create strong and sophisticated interiors mixing daring colors and beautiful materials.

pro@lachance.paris

PRODUCTS INFORMATION



NOTE DESIGN STUDIO





BOLT

Stool ●● 2012



MATERIALS & FINISHES

FINISHES

-  Black stained ash, copper ring
-  Black stained ash, lazer blue ring
-  Natural ash, orange ring
-  Natural ash, lavachrome ring

MATERIALS

- Solid wood (ash)
- Steel (lacquered/plated)

DIMENSIONS & WEIGHT

	BOLT	WITH PACKAGING
HEIGHT	41cm/16in.	46cm/18,1in.
WIDTH	45cm/17,7in.	50cm/19,7in.
DEPTH	45cm/17,7in.	50cm/19,7in.
WEIGHT	14kg/31lbs.	16kg/35,3lbs.

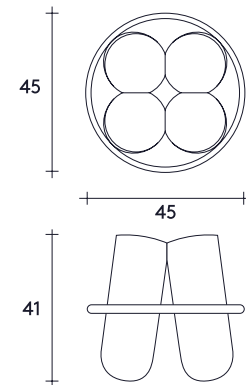

OTHER DETAILS

TECHNICAL INFORMATION	Delivery : In stock
PACKAGING	1 thick cardboard box
MAINTENANCE	Always use a microfiber cloth and rub lightly. Never apply any solvents.



NOTE DESIGN STUDIO



TEMBO

Stool ●● 2012



MATERIALS & FINISHES

FINISHES

-  Shades of black body & mat black metal structure
-  Color body (green, blue, orange and yellow) & shiny lacquered orange structure

MATERIALS

- Solid wood
- Metal
- Lacquered MDF
- Solid cork

DIMENSIONS & WEIGHT

	TEMBO	WITH PACKAGING
HEIGHT	46, 66 or 76cm/ 18, 26 or 29,9in.	50, 70 or 80cm/ 20, 28 or 32 in.
WIDTH	36cm/14in.	40cm/16in.
DEPTH	36cm/14in.	40cm/16in.
WEIGHT	14, 16 or 17kg/ 30, 35 or 37lbs.	16, 18 or 20kg/ 35, 40 or 44lbs.

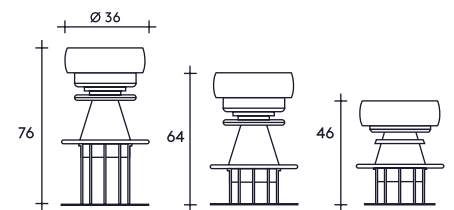

OTHER DETAILS

TECHNICAL INFORMATION	3 sizes available Delivery : in stock
PACKAGING	1 thick cardboard box
MAINTENANCE	Always use a microfiber cloth and rub lightly. Never apply any solvents.



FREDERIK WERNER & EMIL LAGONI VALBAK

RONIN

Chair ●● 2015



JEAN-BAPTISTE SOULETIE



PLANET

Chair ●● 2019



MATERIALS & FINISHES

FINISHES

-  Mat black stained ash
White Pele de tigre marble
Vegan black leather
-  Mat black stained ash
Vegan black leather
-  Custom upholstery and stone

MATERIALS

- Solid wood (ash)
- Marble
- Polyurethane foam
- Vegan leather

DIMENSIONS & WEIGHT

	RONIN	WITH PACKAGING (2 pieces)
HEIGHT	69cm/27in.	106cm/41,8in.
WIDTH	62cm/24,5in.	70cm/27,6in.
DEPTH	46cm/18in.	60cm/23,7in.
WEIGHT	5,5 to 7,5kg/ 11 to 15,4lbs.	30 to 32,5kg/ 66 to 70,5lbs.

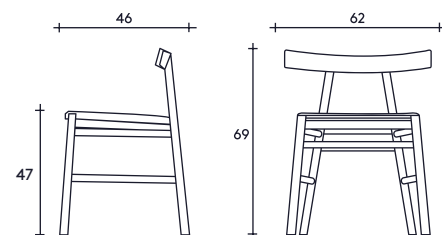

OTHER DETAILS

TECHNICAL INFORMATION	Delivery: in stock Set of 2 chairs Upholstery: selection of fabrics from Kvadrat, Gabriel and Pierre Frey. Client's fabric : 1m based on 1,40m roll, must be approved.
PACKAGING	1 thick cardboard box
MAINTENANCE	Always use a microfiber cloth and rub lightly. Never apply any solvents.

MATERIALS & FINISHES

FINISHES

-  Carmin "Tipi" fabric
Black stained solid ash
Mat lacquered black structure
-  Custom upholstery on demand

MATERIALS

- Solid wood (ash)
- Steel
- Wool

DIMENSIONS & WEIGHT

	PLANET	WITH PACKAGING (2 pieces)
HEIGHT	77,6cm/171in.	80cm/176,4in.
WIDTH	46,7cm/103in.	50cm/110,2in.
DEPTH	47,7cm/105in.	50cm/110,2in.
WEIGHT	6kg/13lbs.	14kg/31lbs.

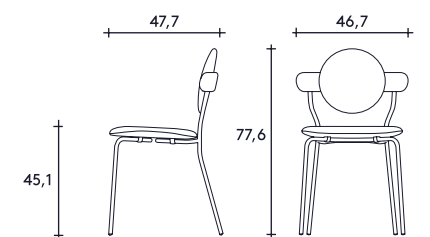

OTHER DETAILS

TECHNICAL INFORMATION	Delivery: 8 weeks Set of 2 chairs Upholstery: selection of fabrics from Kvadrat, Gabriel and Pierre Frey. Client's fabric : 1m based on 1,40m roll, must be approved.
PACKAGING	1 thick cardboard box
MAINTENANCE	Always use a microfiber cloth and rub lightly. Never apply any solvents.



NOÉ DUCHAUFOR LAWGRANCE

BORGHESE

Sofa (2 seaters) ●● 2012







NOÉ DUCHAUFOR LAWGRANCE

BORGHESE

Sofa (3 seaters) ●● 2017



MATERIALS & FINISHES

- | | |
|--|---|
| UPHOLSTERY | STRUCTURE |
|  Stone grey |  Mat black |
|  Natural green | |
|  Custom upholstery for each cushion | |

MATERIALS

- Textured steel structure
- High density foam
- Wool

DIMENSIONS & WEIGHT



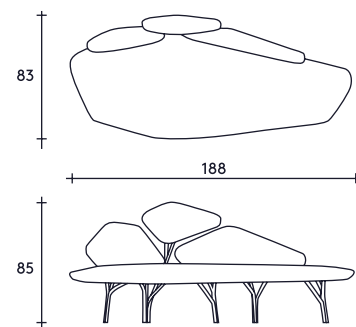

	BORGHESE	WITH PACKAGING
HEIGHT	85cm / 33,5in.	90cm / 35,5in.
DEPTH	83cm / 32,6in.	80cm / 31,5in.
WIDTH	188cm / 74in.	190cm / 75in.
WEIGHT	65kg / 134lbs.	90kg / 198lbs.



OTHER DETAILS

- | | |
|------------------------------|---|
| TECHNICAL INFORMATION | Delivery : 10 weeks
Upholstery: selection of fabrics from Kvadrat and Pierre Frey. |
| PACKAGING | 1 wooden crate |
| MAINTENANCE | Always use a microfiber cloth and rub lightly. Never apply solvents. |

MATERIALS & FINISHES

- | | |
|--|---|
| UPHOLSTERY | STRUCTURE |
|  Stone grey |  Mat black |
|  Natural green | |
|  Custom upholstery for each cushion | |

MATERIALS

- Textured steel structure
- High density foam
- Wool

DIMENSIONS & WEIGHT

	BORGHESE	WITH PACKAGING
HEIGHT	85cm / 33,5in.	90cm / 35,5in.
DEPTH	89cm / 35in.	115cm / 45,5in.
WIDTH	248cm / 97,5in.	260cm / 102in.
WEIGHT	85kg / 187lbs.	115kg / 253lbs.

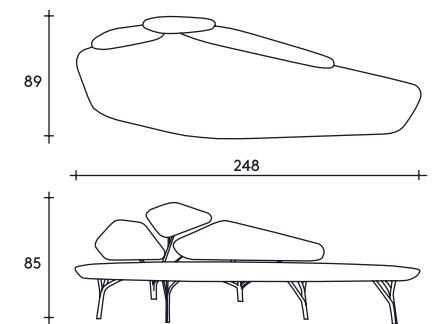

OTHER DETAILS

- | | |
|------------------------------|---|
| TECHNICAL INFORMATION | Delivery : 10 weeks
Upholstery: selection of fabrics from Kvadrat and Pierre Frey. |
| PACKAGING | 1 wooden crate |
| MAINTENANCE | Always use a microfiber cloth and rub lightly. Never apply solvents. |



JONAS LUTZ
BLOCK
Armchair ● 2019



ALAIN GILLES
X RAY ARMCHAIR
Armchair ● 2017



MATERIALS & FINISHES

- | | | |
|--------------------------|------------------------|-----------------------|
| LEGS | SEAT & BACK | ARMRESTS |
| Brass plated | Light grey sheepskin | Natural walnut veneer |
| Mat textured black steel | Black "Tempt" fabric | |
| | Orange "Gaja" fabric | |
| | Custom upholstery | |

DIMENSIONS & WEIGHT

	BLOCK	WITH PACKAGING
HEIGHT	74,2cm / 29,2in.	80cm / 31,5in.
WIDTH	74,2cm / 29,2in.	80cm / 31,5in.
DEPTH	68,7cm / 27in.	80cm / 31,5in.
WEIGHT	20kg / 44lbs	23kg / 50,7lbs

OTHER DETAILS

- TECHNICAL INFORMATION** Delivery: 10 weeks
Each sofa is custom made according to the specifications of each client chosen among the range of leathers (full anilin, semi anilin), fabrics (Pierre Frey, Gabriel, Kvadrat), or client's fabric.
- PACKAGING** 1 cardboard box
- MAINTENANCE** Always use a soft brush and rub lightly. Never apply any solvents.

MATERIALS & FINISHES

- | | |
|--|---------------------------|
| FINISHES | MATERIALS |
| Black and white steel structure, black mat ash armrest | - Tube structure in steel |
| Custom upholstery and structure | - Back in flat steel |
| | - Sitting strap |
| | - Foam cushions |
| | - Solid wood (ash) |

DIMENSIONS & WEIGHT

	X RAY	WITH PACKAGING
HEIGHT	76cm / 30in.	86cm / 33,5in.
WIDTH	110cm / 43,5in.	120 cm / 47,3in.
DEPTH	86cm / 33,5in.	96 cm / 37,8in.
WEIGHT	30kg / 66,1lbs	45kg / 99,2lbs

OTHER DETAILS

- TECHNICAL INFORMATION** Delivery: 10 weeks
Each sofa is custom made according to the specifications of each client chosen among the range of leathers (full anilin, semi anilin), fabrics (Pierre Frey, Gabriel, Kvadrat), or client's fabric.
- PACKAGING** 1 cardboard box
- MAINTENANCE** Always use a soft brush and rub lightly. Never apply any solvents.



ALAIN GILLES

X RAY SOFA 200/250

Sofa ●● 2015



ALAIN GILLES

X RAY DAYBED

Daybed ●● 2017



MATERIALS & FINISHES

FINISHES

 Black and white steel structure, black mat ash armrest

 Custom upholstery and structure

MATERIALS

- Tube structure in steel
- Back in flat steel
- Sitting strap
- Foam cushions
- Solid wood (ash)

DIMENSIONS & WEIGHT

	X RAY	WITH PACKAGING
HEIGHT	76cm / 30in.	86cm / 33,5in.
WIDTH	200 or 250cm / 78,7 or 98,5in.	205 or 255cm / 80,7 or 100,4in.
DEPTH	86cm / 33,5in.	96cm / 37,8in.
WEIGHT	90 or 100kg / 198 or 220lbs.	110 or 120kg / 242 or 264lbs.

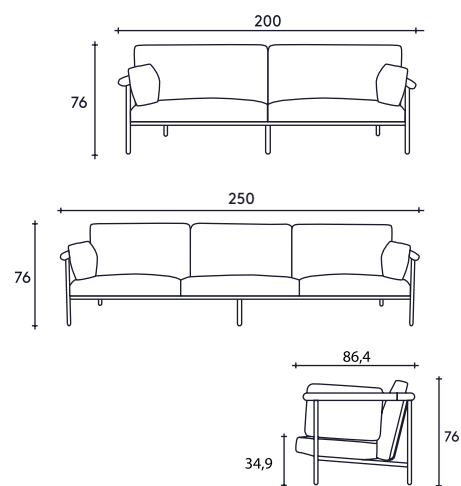



OTHER DETAILS

TECHNICAL INFORMATION	Delivery: 10 weeks Each sofa is custom made according to the specifications of each client chosen among the range of leathers (full anilin, semi anilin), fabrics (Pierre Frey, Gabriel, Kvadrat), or client's fabric.
PACKAGING	1 cardboard box
MAINTENANCE	Always use a soft brush and rub lightly. Never apply any solvents.

MATERIALS & FINISHES

FINISHES

 Black steel structure black mat ash armrest

 Custom upholstery and structure

MATERIALS

- Tube structure in steel
- Back in flat steel
- Sitting strap
- Foam cushions
- Solid wood (ash)

DIMENSIONS & WEIGHT

	X RAY	WITH PACKAGING
HEIGHT	40cm / 15,8in.	50cm / 17,7in.
WIDTH	185cm / 72,3in.	210cm / 74,8in.
DEPTH	86cm / 33,5in.	110cm / 37,8in.
WEIGHT	90kg / 198,4lbs	110kg / 242,5lbs

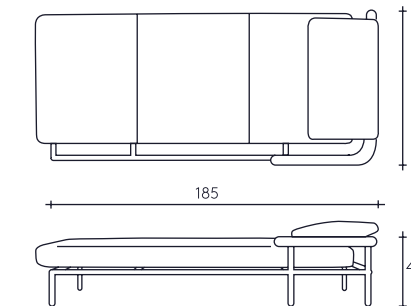

OTHER DETAILS

TECHNICAL INFORMATION	Delivery: 10 weeks Each sofa is custom made according to the specifications of each client chosen among the range of leathers (full anilin, semi anilin), fabrics (Pierre Frey, Gabriel, Kvadrat), or client's fabric.
PACKAGING	1 cardboard box
MAINTENANCE	Always use a soft brush and rub lightly. Never apply any solvents.



JEAN-BAPTISTE SOULETIE

SUNDAY

Bed ●● 2018

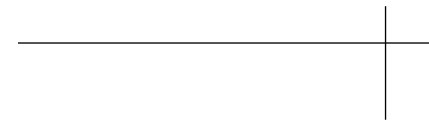

MATERIALS & FINISHES

LEGS

 White mat
Pele de Tigre marble

 Black varnished
Marquina marble

B Choose your marble

FRAME

 Solid walnut

UPHOLSTERY

B Custom upholstery

MATERIALS

- Marble
- Solid walnut
- Fabrics
- Steel

DIMENSIONS & WEIGHT

	SUNDAY BED	WITH PACKAGING
HEIGHT	127cm / 50in. (1) 35cm / 13,8in. (2)	(1) 25x15x15cm / 9,8x5,9x5,9in. (2) 260x60x210cm / 102,4x23,6x82,7in. (3) 15x195x80cm / 5,9x76,8x31,5in. 2x (4) 25x85x15cm / 9,8x33,5x5,9in.
LENGTH	236cm / 92,9in.	(1) 10kg / 22lbs. (2) 110kg / 242,5lbs. (3) 35kg / 77,2lbs. (4) 35kg / 77,2lbs.
WIDTH	200cm / 78,7in.	
WEIGHT	1. 170kg / 374,8lbs. 2. 140kg / 308,6lbs.	

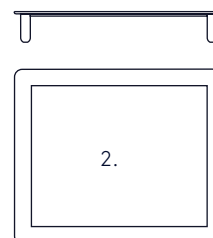
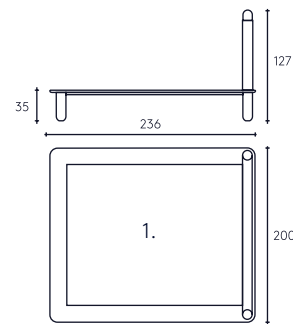

OTHER DETAILS

TECHNICAL INFORMATION	Delivery: 10 weeks Needs assembly. Marble is a natural product. Shade and pattern may vary between two beds. Mattress not included.
PACKAGING	4 thick cardboard boxes and 1 wooden crate
MAINTENANCE	Always use a microfiber cloth and rub lightly. Never apply any solvents.



JONAH TAKAGI

MEWOMA 120

Table ●● 2015

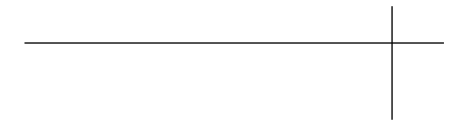

MATERIALS & FINISHES

FINISHES

 White Pele de tigre marble

 Black Marquina marble

 Indian green marble

MATERIALS

- Metal base
- Light oak veneer
- Marble

DIMENSIONS & WEIGHT

	MEWOMA	WITH PACKAGING
HEIGHT	74cm / 29,2 in.	130x100x145cm / 51,2x39,4x57,2in.
DIAMETER	120cm / 47,3in.	95x95x80cm / 37,4x37,4x31,5in.
WEIGHT	90kg / 199lbs.	90x90x5cm / 35,5x35,5x2in.
		125kg / 275lbs.

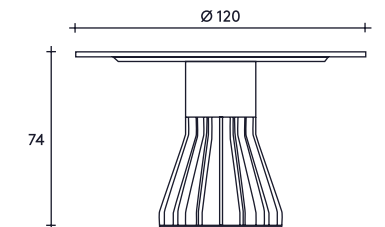

OTHER DETAILS

TECHNICAL INFORMATION	Delivery: 6 to 8 weeks Needs assembly Marble is a natural product. Shade and pattern may vary between two tables.
PACKAGING	2 thick cardboard boxes and 1 wooden crate
MAINTENANCE	Always use a microfiber cloth and rub lightly. Never apply any solvents.



JONAH TAKAGI
MEWOMA 150
Table ●● 2015

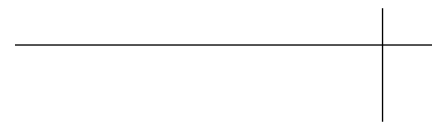

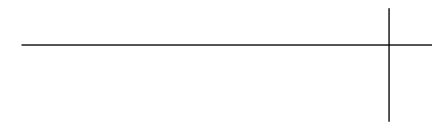

JONAH TAKAGI
MEWOMA DOUBLE
Table ●● 2017



MATERIALS & FINISHES

FINISHES

-  White Pele de tigre marble
-  Black Marquina marble
-  Indian green marble

MATERIALS

- Metal base
- Light oak veneer
- Marble

DIMENSIONS & WEIGHT

	MEWOMA	WITH PACKAGING
HEIGHT	74cm / 29,2in.	160x100x180cm / 63x39,4x70,9in.
DIAMETER	150cm / 59,1in.	95x95x80cm / 37,4x37,4x31,5in.
WEIGHT	110kg / 243lbs.	125kg / 275lbs.

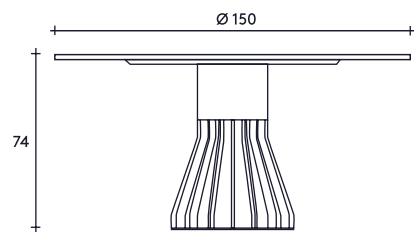







OTHER DETAILS

TECHNICAL INFORMATION	Delivery: 6 to 8 weeks Needs assembly Marble is a natural product. Shade and pattern may vary between two tables.
PACKAGING	2 thick cardboard boxes and 1 wooden crate
MAINTENANCE	Always use a microfiber cloth and rub lightly. Never apply any solvents.

MATERIALS & FINISHES

FINISHES

-  Dark blue stained solid ash
-  Black stained solid ash
-  White Pele de tigre marble
-  Black Marquina marble
-  Indian green marble
-  Choose you essence of wood

MATERIALS

- Metal base
- Ash solid wood
- Marble

DIMENSIONS & WEIGHT

	MEWOMA	WITH PACKAGING
HEIGHT	74cm / 29,2in.	310x130x30cm / 122x51,2x11,9in.
WIDTH	260 or 300cm / 102,4 or 118,2in.	95x95x80cm / 37,4x37,4x31,5in.
DEPTH	110cm / 43,4in.	90x90x5cm / 35,5x35,5x2in.
WEIGHT	150kg / 330lbs.	190kg / 418lbs.

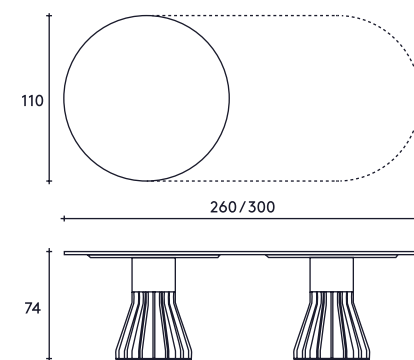

OTHER DETAILS

TECHNICAL INFORMATION	Delivery: 6 to 8 weeks Needs assembly
PACKAGING	4 thick cardboard boxes and 1 wooden crate
MAINTENANCE	Always use a microfiber cloth and rub lightly. Never apply any solvents.



JEAN-BAPTISTE SOULETIE

SUNDAY

Table ●● 2018



JEAN-BAPTISTE SOULETIE

SUNDAY

Coffee table ●● 2018



MATERIALS & FINISHES

LEGS	TOP	
White Pele de Tigre marble	Solid walnut	White Pele de Tigre marble
Black Marquina marble	Black stained ash	Black Marquina marble
Indian green marble	B Choose your essence of wood	Indian green marble
B Choose your marble		

DIMENSIONS & WEIGHT

	SUNDAY	WITH PACKAGING	
HEIGHT	74.5cm / 29,1in.	80x45x30cm / 31,5x17,7x11,8in.	(1)
WIDTH	150 or 200cm / 59 or 78,7in.	(1) 205x55x5cm / 80,7x21,6x1,9in.	(2)
DEPTH	50 or 100cm / 19,6 or 39,4in.	(2) 155x55x5cm / 61x21,6x1,9in.	(3)
WEIGHT	(1) 88kg / 194lbs. (2) 84kg / 185lbs. (3) 104kg / 229lbs. (4) 96kg / 211,6lbs.	(3) 205x105x5cm / 80,7x41,3x1,9in. (4) 155x105x5cm / 61x41,3x1,9in.	(4)

OTHER DETAILS

TECHNICAL INFORMATION	Delivery: 10 to 12 weeks Needs assembly. Screws included. Marble is a natural product. Shade and pattern may vary between two tables.
PACKAGING	1 thick cardboard box and 2 wooden crates
MAINTENANCE	Always use a microfiber cloth and rub lightly. Never apply any solvents.

MATERIALS & FINISHES

LEGS	TOP	
White Pele de Tigre marble	Solid walnut	White Pele de Tigre marble
Black Marquina marble	Black stained ash	Black Marquina marble
Indian green marble	B Choose your essence of wood	Indian green marble
B Choose your marble		

DIMENSIONS & WEIGHT

	SUNDAY	WITH PACKAGING	
HEIGHT	35cm / 13,7in.	40x50x30cm / 15,7x20x11,8in.	(1)
WIDTH	150 or 200cm / 59 or 78,7in.	(1) 205x55x5cm / 80,7x21,6x1,9in.	(2)
DEPTH	50 or 100cm / 19,6 or 39,4in.	(2) 155x55x5cm / 61x21,6x1,9in.	(3)
WEIGHT	(1) 52kg / 114,6lbs. (2) 48kg / 105,8lbs. (3) 68kg / 149,9lbs. (4) 60kg / 132,3lbs.	(3) 205x105x5cm / 80,7x41,3x1,9in. (4) 155x105x5cm / 61x41,3x1,9in.	(4)

OTHER DETAILS

TECHNICAL INFORMATION	Delivery: 10 to 12 weeks Needs assembly. Screws included. Marble is a natural product. Shade and pattern may vary between two tables.
PACKAGING	1thick cardboard box and 1 wooden crate
MAINTENANCE	Always use a microfiber cloth and rub lightly. Never apply any solvents.



SEBASTIAN HERKNER
SALUTE HIGH
Side table ●● 2013



SEBASTIAN HERKNER
SALUTE MEDIUM
Side table ●● 2013



MATERIALS & FINISHES

TRAY	COLUMN
Mat yellow lacquered steel	White Pele de Tigre marble
Mat black lacquered steel	Black Marquina marble
Copper painted steel	Indian green marble
Chrome	B Choose your stone

MATERIALS
- Painted steel
- Marble

DIMENSIONS & WEIGHT

	SALUTE HIGH	WITH PACKAGING
HEIGHT	57cm/22,4in.	73cm/28,7in.
WIDTH	42cm/16,5in.	60cm/23,6in.
DEPTH	32cm/12,6in.	45cm/17,7in.
WEIGHT	43kg/95lbs.	55kg/121lbs.

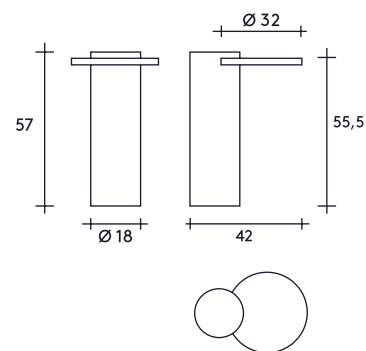

OTHER DETAILS

TECHNICAL INFORMATION	Delivery : 8 to 10 weeks Marble is a natural product. Shade and pattern may vary between two tables.
PACKAGING	1 wooden crate
MAINTENANCE	Always use a microfiber cloth and rub lightly. Never apply any solvents.

MATERIALS & FINISHES

TRAY	COLUMN
Mat yellow lacquered steel	White Pele de Tigre marble
Mat black lacquered steel	Black Marquina marble
Copper painted steel	Indian green marble
Chrome	B Choose your stone

MATERIALS
- Painted steel
- Marble

DIMENSIONS & WEIGHT

	SALUTE MEDIUM	WITH PACKAGING
HEIGHT	46cm/18,1in.	61cm/24,3in.
WIDTH	40cm/15,8in.	60cm/23,6in.
DEPTH	40cm/15,8in.	54cm/21,3in.
WEIGHT	34kg/75lbs.	50kg/110lbs.

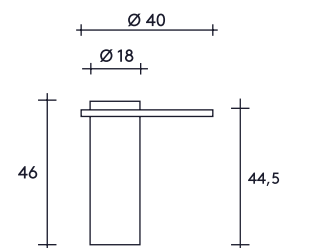

OTHER DETAILS

TECHNICAL INFORMATION	Delivery : 8 to 10 weeks Marble is a natural product. Shade and pattern may vary between two tables.
PACKAGING	1 wooden crate
MAINTENANCE	Always use a microfiber cloth and rub lightly. Never apply any solvents.

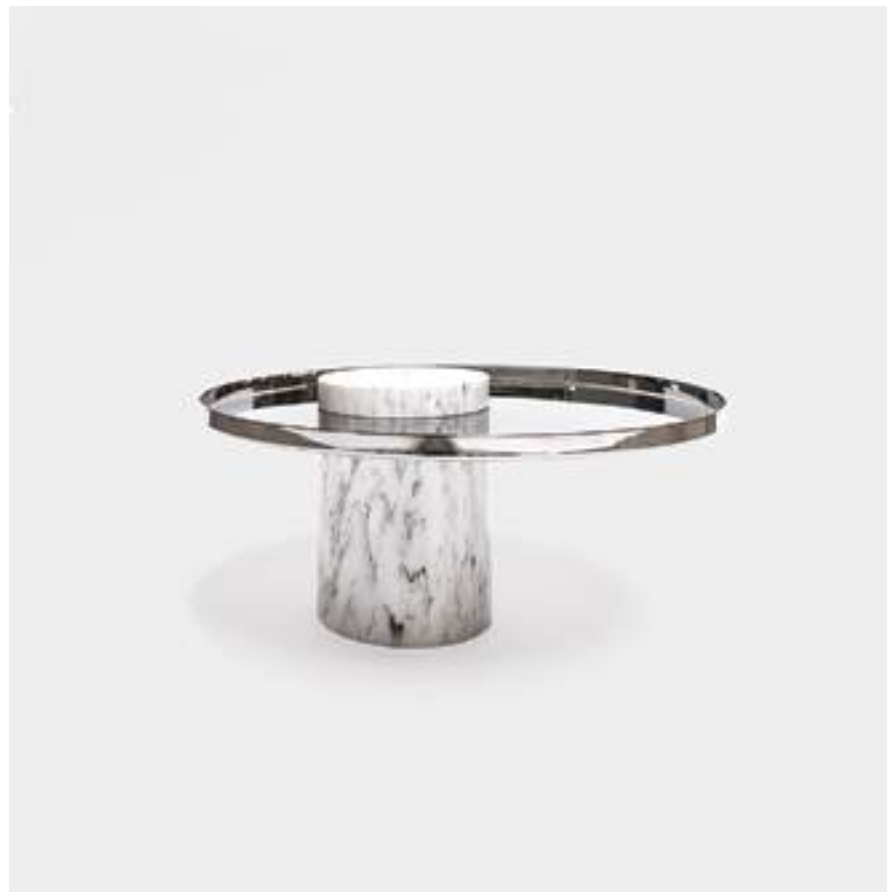

SEBASTIAN HERKNER
SALUTE LOW
Side table ●● 2013



MATERIALS & FINISHES

TRAY	COLUMN
Mat yellow lacquered steel	White Pele de Tigre marble
Mat black lacquered steel	Black Marquina marble
Copper painted steel	Indian green marble
Chrome	B Choose your stone

MATERIALS
- Painted steel
- Marble

DIMENSIONS & WEIGHT

	SALUTE LOW	WITH PACKAGING
HEIGHT	33cm / 18,1in.	86cm / 33,9in.
WIDTH	70cm / 27,6in.	92cm / 36,2in.
DEPTH	70cm / 27,6in.	45cm / 17,7in.
WEIGHT	65kg / 143lbs.	82kg / 180lbs.

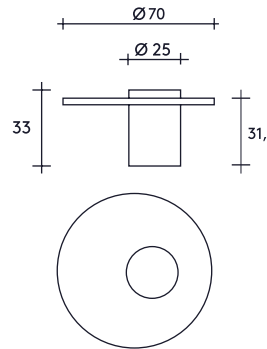

OTHER DETAILS

TECHNICAL INFORMATION	Delivery : 8 to 10 weeks Marble is a natural product. Shade and pattern may vary between two tables.
PACKAGING	1 wooden crate
MAINTENANCE	Always use a microfiber cloth and rub lightly. Never apply any solvents.



LUCA NICHETTO
FLOAT
Coffee table ●● 2012



MATERIALS & FINISHES

CONE	MATERIALS
Shiny lacquered yellow	- Steel cone base
Shiny lacquered blue	- Mirror polished steel / MDF base
Mat aluminium paint	
Mat black paint	
B Custom color & finishes	

DIMENSIONS & WEIGHT

	FLOAT	WITH PACKAGING
HEIGHT	31cm / 51,5in.	130cm / 51,2in.
WIDTH	118cm / 46,5 in.	50cm / 19,7in.
DEPTH	118cm / 46,5in.	130cm / 51,2in.
WEIGHT	35kg / 77lbs.	50kg / 110lbs.

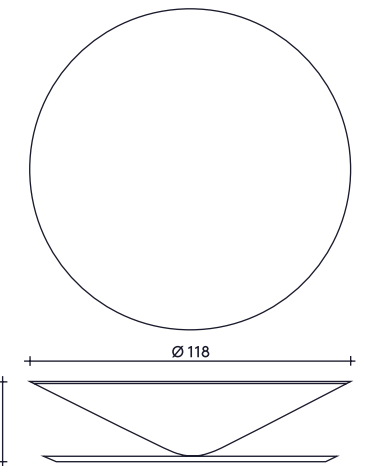

OTHER DETAILS

TECHNICAL INFORMATION	Delivery: 8 weeks
PACKAGING	1 thick cardboard box & wooden craft
MAINTENANCE	Always use a microfiber cloth and rub lightly. Never apply any solvents.



NOÉ DUCHAUFOUR LAWRENCE

BORGHESE

Coffee table ●● 2014



NOTE DESIGN STUDIO



ZORRO

Coffee table ●● 2012



MATERIALS & FINISHES

FINISHES

-  Black steel structure, mat natural wood top
-  Black steel structure, mat black stained wood top

MATERIALS

- Solid oak
- Textured steel structure

DIMENSIONS & WEIGHT

	BORGHESE	WITH PACKAGING
HEIGHT	35cm / 13,8in.	45cm / 17,7in.
WIDTH	139cm / 54,7in.	143cm / 56,3in.
DEPTH	64cm / 25,2in.	70cm / 27,6in.
WEIGHT	25kg / 55lbs.	29kg / 63lbs.

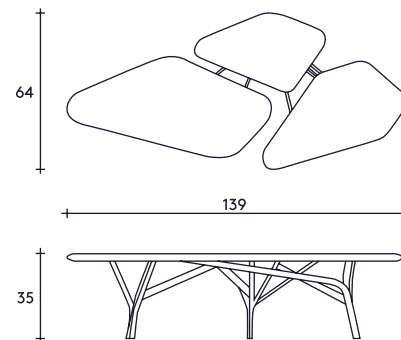



OTHER DETAILS

TECHNICAL INFORMATION	Delivery: in stock
PACKAGING	1 cardboard box
MAINTENANCE	Always use a microfiber cloth and rub lightly. Never apply any solvents.

MATERIALS & FINISHES

FINISHES

-  Blue structure, two glass tops
-  Chrome structure, smoked glass, white Pele de Tigre marble
-  Chrome structure, smoked glass, black Marquina marble

MATERIALS

- Steel structure
- Glass
- Marble top

DIMENSIONS & WEIGHT

	ZORRO	WITH PACKAGING
HEIGHT	36cm / 14in.	- 104x85x8cm / 50x33,5x3,2in. (Zorro blue)
WIDTH	108cm / 42,5in.	
DEPTH	80cm / 31,5in.	
DIAMETER	60 & 80cm / 23,6 & 31,5in.	- 104x85x8cm / 50x33,5x3,2in. - 100x100x12cm / 39,5x39,5x7,7in. (Zorro marble)
WEIGHT	17 or 27kg / 37 or 59lbs.	20 or 62kg / 44 or 136lbs.

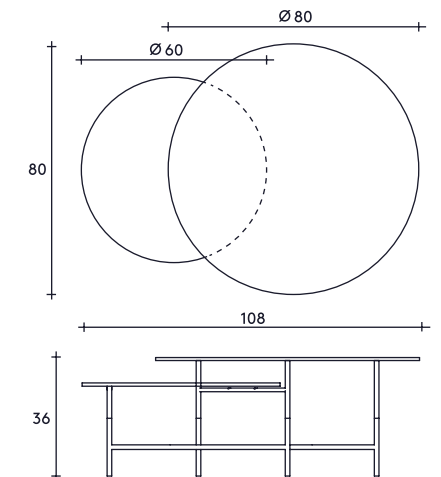

OTHER DETAILS

TECHNICAL INFORMATION	Delivery : in stock Need assembly Marble is a natural product. Shade and pattern may vary between two tables.
PACKAGING	1 thick cardboard box / 1 thick cardboard box & 1 wooden crate for marble version.
MAINTENANCE	Always use a microfiber cloth and rub lightly. Never apply any solvents.



BASHKO TRYBEK
CLIMB
Shelving system ●● 2012

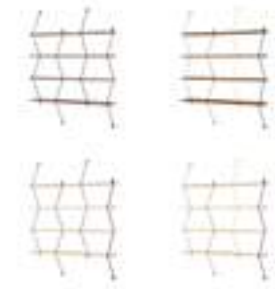

BASHKO TRYBEK
CLIMB MEGA
Shelving system ●● 2017



MATERIALS & FINISHES

- | | |
|--|---|
| STRUCTURE | SHELVES |
| <ul style="list-style-type: none"> Black wires Yellow, blue, red and black wires B Choose colors of wires available on demand | <ul style="list-style-type: none"> Natural varnished walnut Natural varnished birch |

- MATERIALS**
- Steel
 - Wood (Birch/Walnut)

DIMENSIONS & WEIGHT

	CLIMB	WITH PACKAGING
HEIGHT	155cm / 61in.	15cm / 5,9in.
WIDTH	120cm / 47,2 in.	120 cm / 47,2in.
DEPTH	22cm / 8,7in.	22cm / 24in.
WEIGHT	12 kg / 26 lbs.	14kg / 30 lbs.

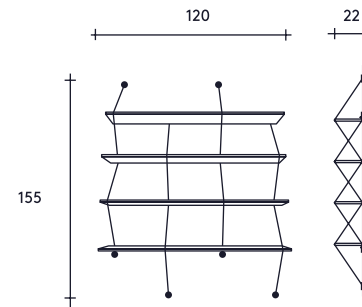

OTHER DETAILS

- | | |
|------------------------------|--|
| TECHNICAL INFORMATION | Delivery : in stock
Needs assembly
Screws are included. |
| PACKAGING | 1 thick cardboard box |
| MAINTENANCE | Always use a microfiber cloth and rub lightly. Never apply any solvents. |

MATERIALS & FINISHES

- | | | |
|--|--|---|
| STRUCTURE | SHELVES | MATERIALS |
| <ul style="list-style-type: none"> Black wires B Choose colors of wires available on demand | <ul style="list-style-type: none"> Natural varnished walnut | <ul style="list-style-type: none"> - Steel - Solid walnut |

DIMENSIONS & WEIGHT

	CLIMB MEGA	WITH PACKAGING
HEIGHT	180cm / 70,1in.	12cm / 4,71in.
WIDTH	135cm / 53,1in.	135cm / 53,1in.
DEPTH	27cm / 10,6in.	27cm / 10,6in.
WEIGHT	20kg / 44lbs.	23kg / 50lbs.

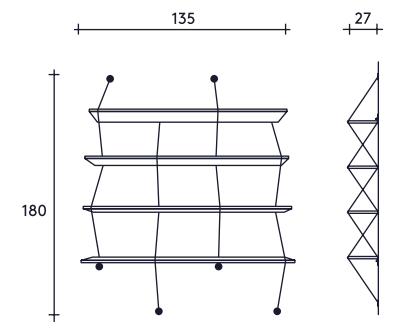

OTHER DETAILS

- | | |
|------------------------------|--|
| TECHNICAL INFORMATION | Delivery: in stock
Needs assembly
Screws are included. |
| PACKAGING | 1 thick cardboard box |
| MAINTENANCE | Always use a microfiber cloth and rub lightly. Never apply any solvents. |



JAN PLECHAC & HENRY WIELGUS



BUMP 2

Credenza ● 2018



MATERIALS & FINISHES

FINISHES

-  White Pele de tigre marble
-  Black Marquina marble
-  Choose your marble on demand

MATERIALS

- Marble
- Black painted wood
- Galvanized doors & side

DIMENSIONS & WEIGHT

	BUMP	WITH PACKAGING
HEIGHT	61,5 or 91,5cm / 24 or 35,4in.	53x98,2x53cm / 20,8x38,7x20,8in.
WIDTH	90,2cm / 35,4in.	53x98,2x7,5cm / 20,8x38,7x2,8in.
DEPTH	45cm / 17,7in.	76,2x21/51x41cm / 30x8,3/20,1x16,1in.
WEIGHT	52 to 54kg / 114,6 to 119lbs.	58 to 60kg / 127,9 to 132,3lbs.

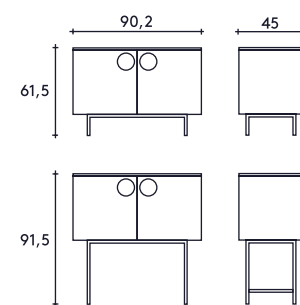

OTHER DETAILS

TECHNICAL INFORMATION	Delivery : 10 weeks Marble is a natural product. Shade and pattern may vary between two credenzas.
PACKAGING	1 wooden crate, 1 cardboard box and feet wrapped in foam.
MAINTENANCE	Always use a dry microfiber cloth and rub lightly. Never apply any solvents.



JAN PLECHAC & HENRY WIELGUS



BUMP 4

Credenza ● 2018



MATERIALS & FINISHES

FINISHES

-  White Pele de tigre marble
-  Black Marquina marble
-  Choose your marble on demand

MATERIALS

- Marble
- Black painted wood
- Galvanized doors & side

DIMENSIONS & WEIGHT

	BUMP	WITH PACKAGING
HEIGHT	61,5cm / 24in.	53x188,6x53cm / 20,8x74,3x20,8in.
WIDTH	180,6cm / 70,9in.	53x188,6x7,5cm / 20,8x74,3x2,8in.
DEPTH	45cm / 17,7in.	143,4x21x41cm / 56,5x8,3x16,1in.
WEIGHT	105kg / 231,5lbs.	127kg / 280lbs.

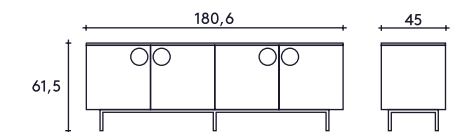

OTHER DETAILS

TECHNICAL INFORMATION	Delivery : 10 weeks Marble is a natural product. Shade and pattern may vary between two credenzas.
PACKAGING	1 wooden crate, 1 cardboard box and feet wrapped in foam.
MAINTENANCE	Always use a dry microfiber cloth and rub lightly. Never apply any solvents.



CHARLES KALPAKIAN

ROCKY

Credenza ●● 2012



MARTA BAKOWSKI

SORCIER

Wall lamp ●● 2016



MATERIAL & FINISHES

FINISHES

- Mat textured dark blue
- Mat textured brick red
- Mat textured black
- Mat textured green

MATERIAL

- Steel

DIMENSIONS & WEIGHT

	ROCKY	WITH PACKAGING
HEIGHT	95cm / 37,4in.	95cm / 37,4in.
WIDTH	140cm / 55in.	152cm / 60in.
DEPTH	36cm / 14,5in.	40cm / 15,8in.
WEIGHT	50kg / 110lbs.	70kg / 154lbs.

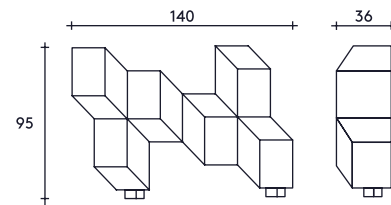

OTHER DETAILS

TECHNICAL INFORMATION	Delivery: 8 to 10 weeks
PACKAGING	1 cardboard box & wooden crate
MAINTENANCE	Always use a microfiber cloth and rub lightly. Never apply any solvents.

MATERIAL & FINISHES

FINISHES

- Black
- White
- Blue and gold
- Blue, light grey and yellow

MATERIAL

Steel

DIMENSIONS & WEIGHT

	SORCIER LAMP	WITH PACKAGING
HEIGHT	46,5cm / 18,3in.	52cm / 20,5in.
WIDTH	22cm / 8,7in.	29cm / 11,4in.
DEPTH	9cm / 3,5in.	15cm / 5,9in.
WEIGHT	1,5kg / 3,3lbs.	3kg / 6,6lbs.

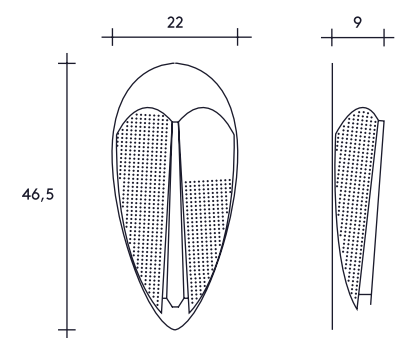

OTHER DETAILS

TECHNICAL INFORMATION	Delivery: in stock E27 / 60W max. Bulb not included.
PACKAGING	1 thick cardboard box
MAINTENANCE	Always use a microfiber cloth and rub lightly. Never apply any solvents.









JONAH TAKAGI
TIP TOP
Table lamp ●● 2012



MATERIALS & FINISHES

- | | |
|--|--|
| BASE | SHADE |
|  Mat lacquered aluminium grey |  Smoky grey glass |
|  Shiny lacquered green | |
|  Shiny lacquered orange | |

- MATERIALS**
- Steel
 - Blown glass

DIMENSIONS & WEIGHT

	TIP TOP LAMP	WITH PACKAGING
HEIGHT	40cm / 15,7 in.	56cm/22in.
WIDTH	30cm / 11,8in.	33cm/13in.
DEPTH	30cm / 11,8in.	36cm/14,2in.
WEIGHT	6kg / 13,5lbs.	7kg / 15lbs.

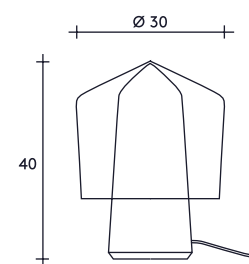

OTHER DETAILS



- TECHNICAL INFORMATION** Delivery: in stock
E27 / 60W max. Bulb not included.
Wire size : 150cm
- Blown glass is an artisanal product and may present slight distortions.
- PACKAGING** 1 thick cardboard box
- MAINTENANCE** Always use a microfiber cloth and rub lightly. Never apply any solvents.



POOL
VULCAIN
Table lamp ●● 2012



MATERIALS & FINISHES

- | | |
|--|----------------------|
| FINISHES | MATERIALS |
|  Mat aluminium grey base
Mat white shade, yellow key | - Steel |
|  White Carrara marble base
Brass finish shade, black key | - Marble |
| | - Cloth covered wire |

DIMENSIONS & WEIGHT

	VULCAIN	WITH PACKAGING
HEIGHT	45 or 55cm / 17,8 or 21,6in.	18x18x45cm / 7,1x7,1x17,7in. (aluminium)
DIAMETER	17 or 20,7cm / 7 or 8,1in.	45x45x20cm / 17,7x17,7x7,9in. (marble)
WEIGHT	2 or 6kg / 4 or 13lbs.	3 or 7kg / 6 or 15lbs.

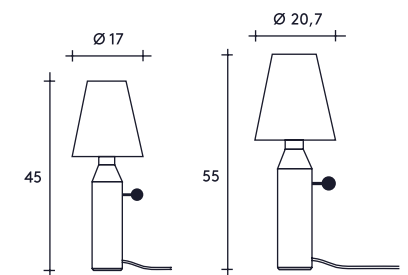

OTHER DETAILS

- TECHNICAL INFORMATION** Delivery: in stock
E14 / 40W max. Bulb not included.
Wire size : 200cm
- 2 sizes :
- 45cm height for the aluminium version
- 55cm height for the marble one.
- Marble is a natural product. Shade and pattern may vary between two lamps.
- PACKAGING** 1 thick cardboard box
- MAINTENANCE** Always use a microfiber cloth and rub lightly. Never apply any solvents.



DAN YEFFET & LUCIE KOLDOVA

APOLLO

Floor lamp ●● 2013



GUILLAUME DELVIGNE



SWAN

Pendant lamp ●● 2013



MATERIALS & FINISHES

FINISHES

-  White Pele de Tigre marble & clear glass
-  Black Marquina marble & clear glass

MATERIALS

- Blown glass
- Marble

DIMENSIONS & WEIGHT

	APOLLO LAMP	WITH PACKAGING
HEIGHT	45cm/17,7in.	54cm/21,3in.
WIDTH	43cm/16,9in.	61cm/24in.
DEPTH	43cm/16,9in.	54cm/21,3in.
WEIGHT	15kg/33lbs.	18kg/40lbs.

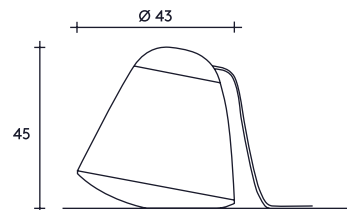

OTHER DETAILS

TECHNICAL INFORMATION	<p>Delivery: 8 weeks LED lighting, wire size : 200cm Voltage : 210 - 220 V max</p> <p>Marble is a natural product. Shade and pattern may vary between two lamps. Blown glass is an artisanal product and may present slight distortions.</p>
PACKAGING	1 thick cardboard box
MAINTENANCE	Always use a microfiber cloth and rub lightly. Never apply any solvents.

MATERIALS & FINISHES

FINISHES

-  Upper shade: Opaline white blown glass
- Lower shade: chromed steel

DIMENSIONS & WEIGHT

	SWAN	WITH PACKAGING
HEIGHT	42cm/16,5in.	50cm/19,7in.
WIDTH	44cm/17,3in.	50cm/19,7in.
DEPTH	44cm/17,3in.	50cm/19,7in.
WEIGHT	8kg/17lbs.	9,5kg/21lbs.

OTHER DETAILS

TECHNICAL INFORMATION	<p>Delivery: in stock E27 / 60W. Bulb not included. Wire size : 250cm</p> <p>Blown glass is an artisanal product and may present slight distortions.</p>
PACKAGING	1 thick cardboard box
MAINTENANCE	Always use a microfiber cloth and rub lightly. Never use any solvents.

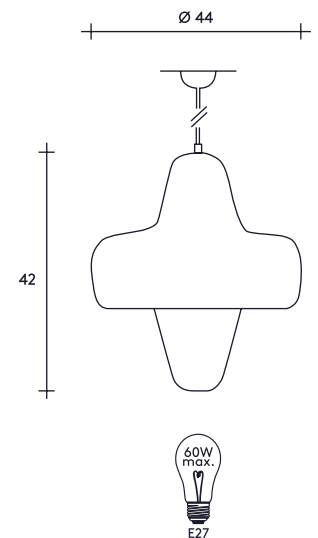



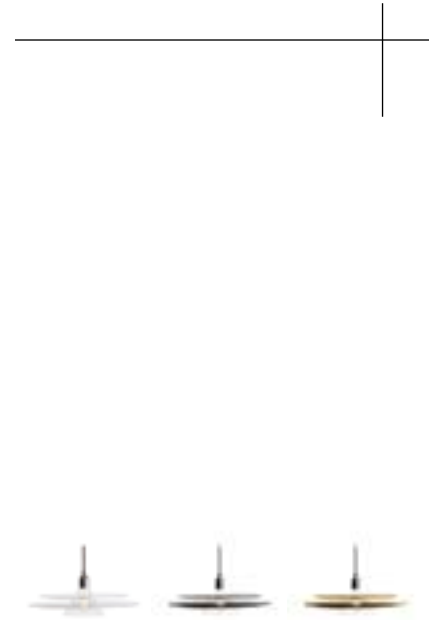

JEAN-BAPTISTE SOULETIE
CYMBAL
Pendant lamp ●● 2015



MATERIALS & FINISHES

- FINISHES
-  Chrome
 -  Mat black
 -  Brass plated

MATERIALS

- Aluminium
- Blown glass
- Cloth covered wire

DIMENSIONS & WEIGHT

	CYMBAL	WITH PACKAGING
HEIGHT	15cm / 6in.	25cm / 9,9in.
WIDTH	47cm / 18,5in.	50cm / 19,7in.
DEPTH	47cm / 18,5in.	50cm / 19,7in.
WEIGHT	0,5kg / 1lbs.	1kg / 2lbs.

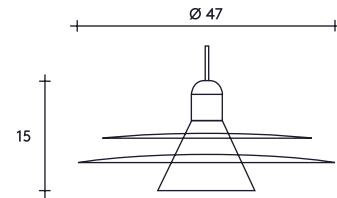

OTHER DETAILS





TECHNICAL INFORMATION	Delivery : in stock Wire size: 250cm E27 / 60W max. Bulb not included.
	Blown glass is an artisanal product and may present slight distortions.
PACKAGING	1 thick cardboard box
MAINTENANCE	Always use a microfiber cloth and rub lightly. Never apply any solvents.



JEAN-BAPTISTE SOULETIE
FAX
Pendant lamp ●● 2019



MATERIALS & FINISHES

- FINISHES
-  White Pele de tigre marble
 -  Black Marquina marble
 -  Indian green marble
 -  Choose your marble on demand

MATERIALS

- Marble
- Brass bolts
- Electric system
- Steel wires

DIMENSIONS & WEIGHT

	FAX	WITH PACKAGING
LENGTH	160cm / 63in.	170cm / 67in.
WIDTH	44,9cm / 17,7in.	70cm / 27,6in.
THICKNESS	2cm / 0,8in.	60cm / 23,7in.
WEIGHT	30kg / 66,1lbs.	60kg / 132,3lbs.

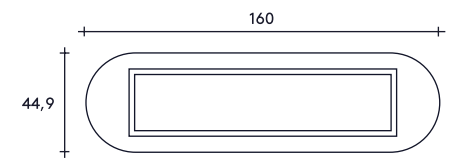
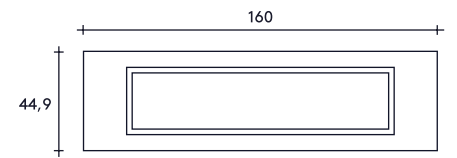
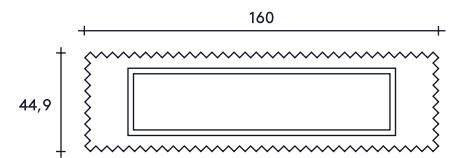

OTHER DETAILS

TECHNICAL INFORMATION	Delivery: 10 to 12 weeks LED dimable system Wire size : 250cm
	Marble is a natural product. Shade and pattern may vary between two lamps.
PACKAGING	1 wooden crate
MAINTENANCE	Always use a microfiber cloth and rub lightly. Never apply any solvents.



DAN YEFFET & LUCIE KOLDOVA

ICONIC

Standing mirror ●● 2012



JACQUES EMILE RUHLMANN





LALOU

Table mirror ●● 2015



MATERIALS & FINISHES

FINISHES

-  Pele de tigre white marble base, white structure
-  Marquina black marble, black structure
-  Oak base, black structure
-  Choose your essence of wood or stone

MATERIALS

- Aluminium structure
- Marble
- Solid oak
- Mirror

DIMENSIONS & WEIGHT

	ICONIC	WITH PACKAGING
HEIGHT	185cm / 72,9in.	- 40x40x80cm / 15,7x15,7x31,5in.
WIDTH	75cm / 29,5in.	- 35x70x140cm / 13,8x27,5x55,1in.
DEPTH	38cm / 15in.	
WEIGHT	70 or 80kg / 154 or 176lbs.	85 or 95kg / 188 or 210lbs.

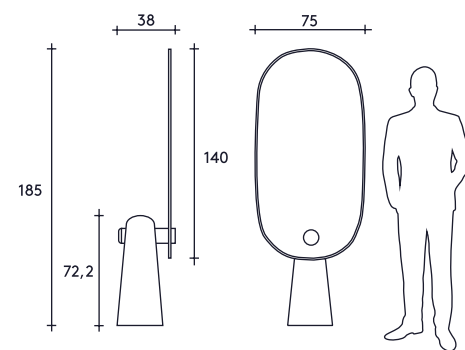



OTHER DETAILS

TECHNICAL INFORMATION	Delivery : 6 weeks Needs assembly Marble is a natural product. Shade and pattern may vary between two mirrors.
PACKAGING	1 wooden crate and 1 cardboard box
MAINTENANCE	Always use a microfiber cloth and rub lightly. Never apply any solvents.

MATERIALS & FINISHES

FINISHES

-  Natural varnished walnut
-  Mat black lacquered birch

MATERIALS

- Solid wood (walnut or birch)
- Mirror

DIMENSIONS & WEIGHT

	LALOU	WITH PACKAGING
HEIGHT	43,5cm / 17,1in.	45cm / 17,7in.
WIDTH	40cm / 15,8in.	45cm / 17,7in.
DEPTH	20cm / 7,9in.	12cm / 4,7in.
WEIGHT	3kg / 6,6lbs.	3,5kg / 7lbs.

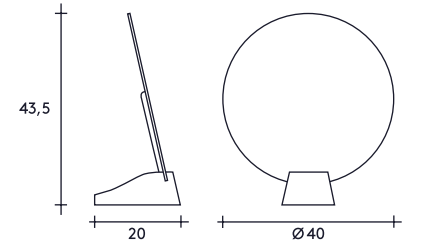

OTHER DETAILS

TECHNICAL INFORMATION	Delivery : in stock Needs assembly
PACKAGING	1 luxury gift box
MAINTENANCE	Always use a microfiber cloth and rub lightly. Never apply any solvents.



TOLILA & GILLILAND
JEEVES
Valet ●● 2013

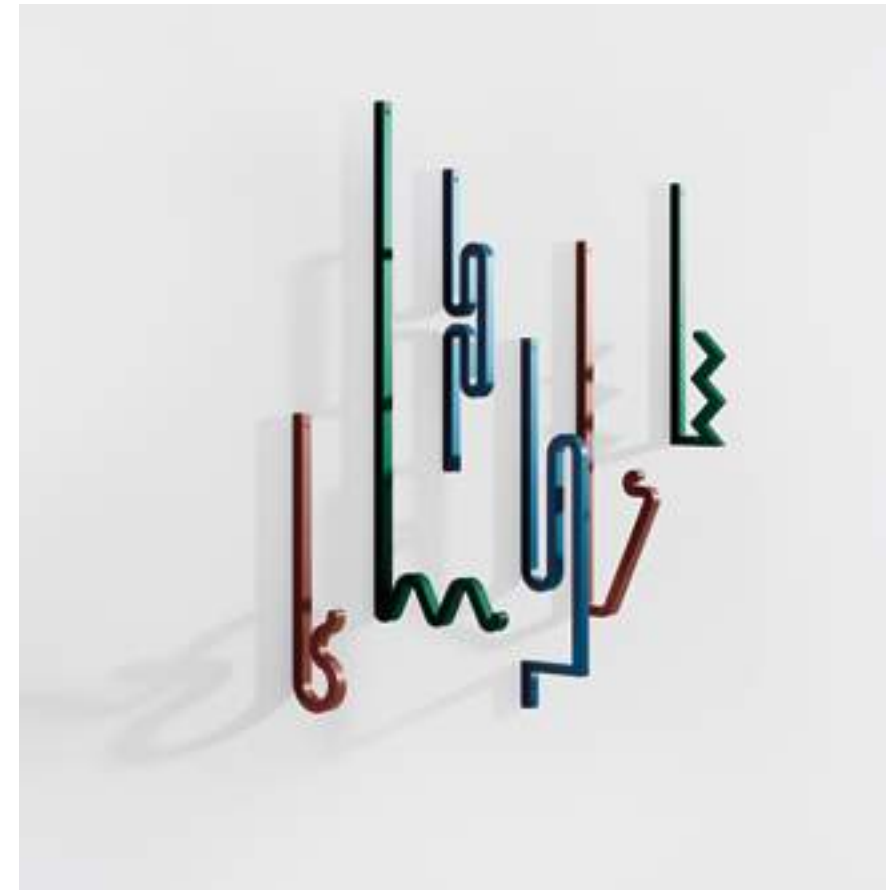



STUDIO BLING
ZAG
Coat hooks ●● 2018



MATERIALS & FINISHES

FINISHES

-  Black stained ash stem & arms
-  Mat varnished walnut stem & mat black ash arms
-  Mat varnished walnut stem & white Pele de Tigre marble arms

MATERIALS

- Solid wood (walnut, ash)
- Marble
- Steel structure

DIMENSIONS & WEIGHT

	JEEVES	WITH PACKAGING
HEIGHT	25cm / 8in.	28cm / 11in.
DEPTH	14cm / 6in.	18cm / 7in.
WIDTH	62cm / 24,4in.	64cm / 25in.
WEIGHT	2 or 5kg / 4,4 or 11lbs.	2 or 5kg / 4,4 or 11lbs.

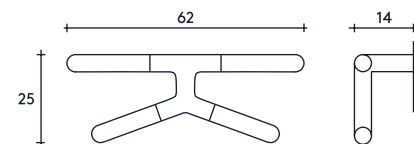



OTHER DETAILS

TECHNICAL INFORMATION	Delivery : in stock Variation of weight depending on materials chosen (5kg for marble finish, 2kg for walnut and black).
PACKAGING	1 gift box
MAINTENANCE	Always use a microfiber cloth and rub lightly. Never apply any solvents.

MATERIALS & FINISHES

FINISHES

-  Mat textured brick red steel
-  Mat textured green steel
-  Mat textured blue steel

MATERIALS

- Steel

DIMENSIONS & WEIGHT

	ZAG	WITH PACKAGING
HEIGHT	A 25,5 or 36,3cm / 10 or 14,3in. B 41 or 26,5cm / 16,1 or 6,3in. C 38 or 27,6cm / 13,6 or 5,4in.	ABC - 80x18x3,2 cm / 31,5x7,1x1,3in.
DEPTH	A 5or9cm / 62or3,5in. B 14 or 6cm / 5,6 or 2,4in. C 8 or 5cm / 2,8or2in.	
WIDTH	ABC 1,2cm / 0,5in.	
WEIGHT	~700 gr / 1,5 lbs.	1,5 kg / 3,3 lbs.

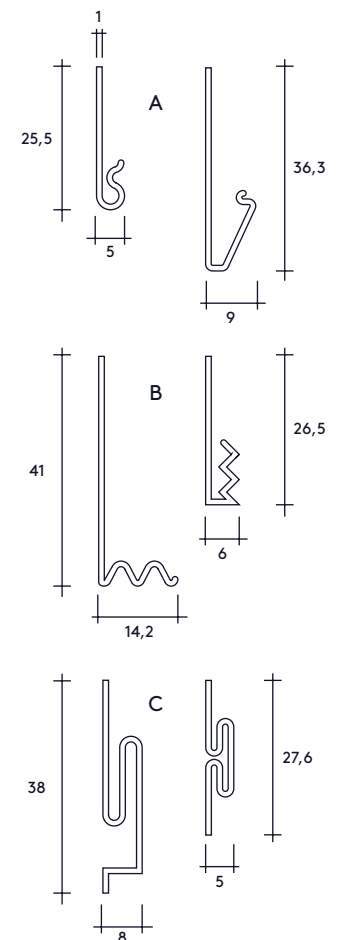

OTHER DETAILS

TECHNICAL INFORMATION	Delivery : in stock Screws included.
PACKAGING	1 luxury gift box
MAINTENANCE	Always use a microfiber cloth and rub lightly. Never apply any solvents.



GUILLAUME DELVIGNE

TOY

Vase ●● 2015

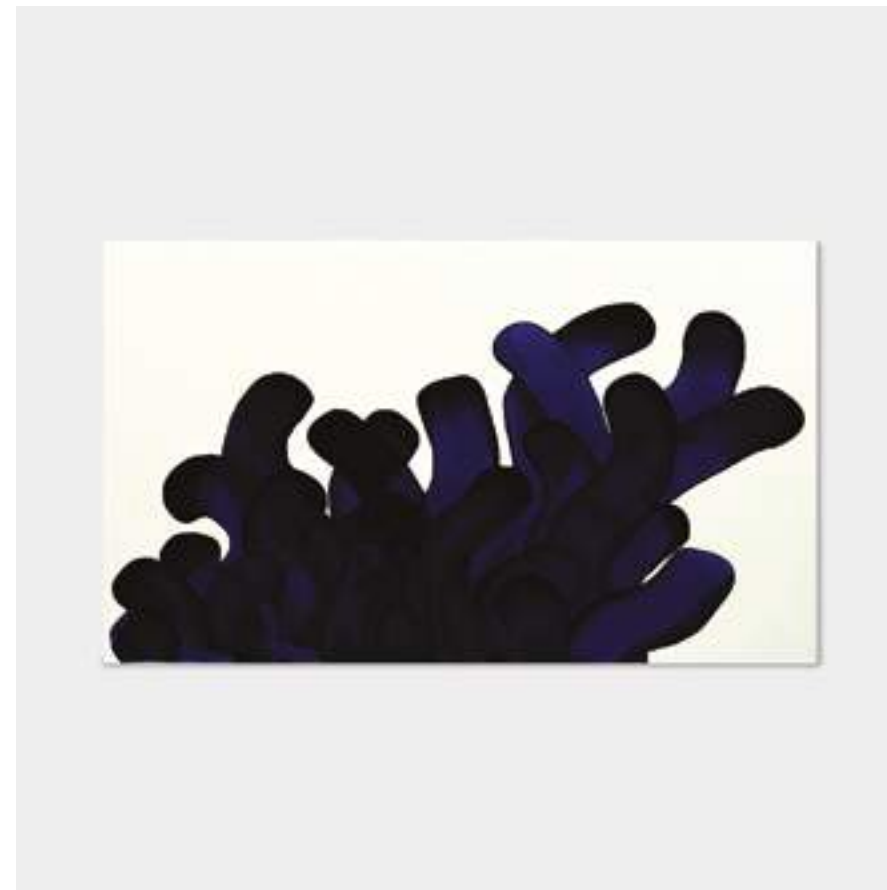

FRANCOIS DUMAS

ANEMONE

Rug ●● 2012



MATERIALS & FINISHES

FINISHES

- Black glass, transparent glass, white lines, pink disc
- Red glass, transparent glass, black lines, blue disc

MATERIALS

- Hand painted blown glass
- Mecanic glass (disc)

DIMENSIONS & WEIGHT

	TOY VASE	WITH PACKAGING
HEIGHT	52cm/20,4in.	53cm/20,8in.
DIAMETER	24cm/9,4in.	30cm/12in. 45cm/17,7in.
WEIGHT	7kg/15lbs.	8,5kg/19lbs.

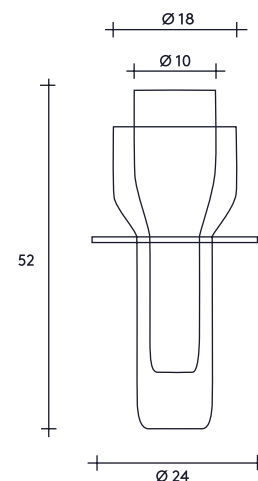

OTHER DETAILS

TECHNICAL INFORMATION	<p>Delivery: in stock</p> <p>Blown glass is an artisanal product and may present slight distortions. Each line is painted by hand and may present irregularities that make the uniqueness of each vase.</p> <p>Numbered editions of 50 by color, delivered with a certificate of authenticity.</p>
PACKAGING	1 luxury gift box
MAINTENANCE	Always use a microfiber cloth and rub lightly. Never apply any solvents.

MATERIALS & FINISHES

FINISHES

- Shades of blue
- Shades of red
- Shades of green
- Shades of grey
- Choose colors available on demand

MATERIALS

- 100% pure wool, hand-tufted

DIMENSIONS & WEIGHT

	STANDARD	BESPOKE
WIDTH	150cm/59,1in.	Colors, size & shape can be custom made according to wishes and measurements of the client.
LENGTH	280cm/110,3in. (rectangular rug)	
DIAMETER	230cm/90,6in. (round rug)	
RATIO	L = Wx1,9	

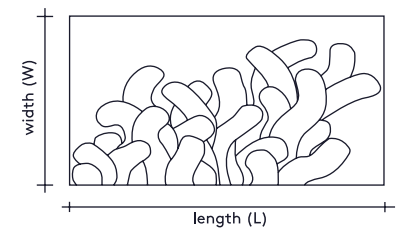

OTHER DETAILS

TECHNICAL INFORMATION	<p>Delivery: 10 weeks</p> <p>All rugs are handcrafted. Every rug is unique and there may be minor variations in size. Wool is dyed by hand in India and slight chromatic variations between a rug and another may be observed.</p>
MAINTENANCE	<p>Vacuum at least once a week (especially during the first months). In case spill happens, use a sponge to remove as much liquid as possible, then use a lightly diluted detergent. Fully dry the rug with a clean cloth.</p>

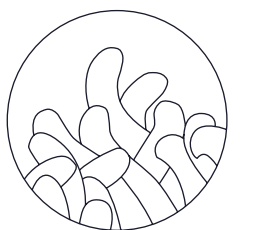



NATHALIE DU PASQUIER

TAPIGRI

Rug ●● 2015

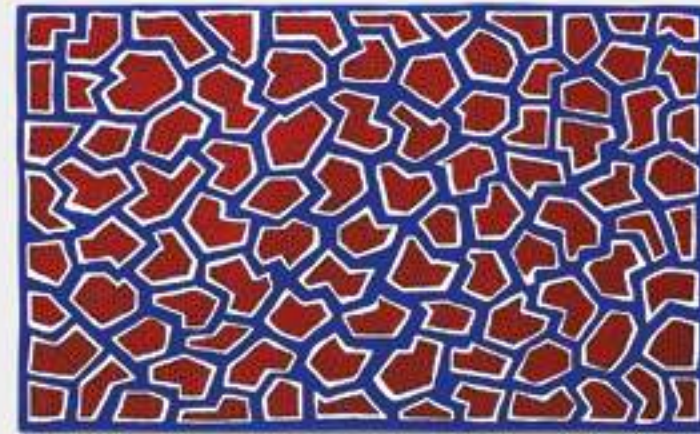

NATHALIE DU PASQUIER

FRANCE

Rug ●● 2013



MATERIALS & FINISHES

FINISHES

-  Shades of grey
-  Color version (Yellow, blue, black)

MATERIALS

100% pure wool, hand tufted

DIMENSIONS & WEIGHT

	STANDARD	BESPOKE
WIDTH	160cm / 62,9in.	Size can be custom made according to wishes and measurements of the client.
LENGTH	240cm / 94,4in.	
RATIO	W = Lx2/3	

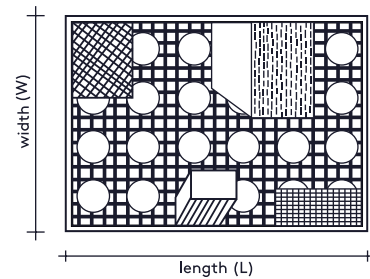

OTHER DETAILS

TECHNICAL INFORMATION	<p>Delivery: 10 weeks</p> <p>All rugs are handcrafted. Every rug is unique and there may be minor variations in size. Wool is dyed by hand in India and slight chromatic variations between a rug and another may be observed.</p>
MAINTENANCE	<p>Vacuum at least once a week (especially during the first months). In case spill happens, use a sponge to remove as much liquid as possible, then use a lightly diluted detergent. Fully dry the rug with a clean cloth.</p>

MATERIALS & FINISHES

FINISHES

-  Blue, red & white with small black lines

MATERIALS

100% pure wool, hand tufted

DIMENSIONS & WEIGHT

	STANDARD	BESPOKE
WIDTH	170cm / 66,9in.	Size can be custom made according to wishes and measurements of the client.
LENGTH	240cm / 94,4in.	
RATIO	W = Lx7/10	

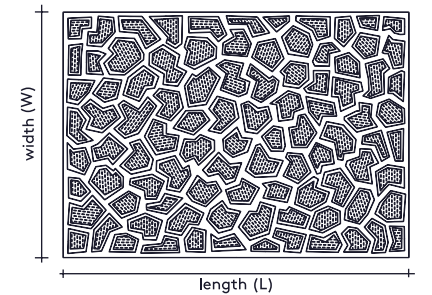

OTHER DETAILS

TECHNICAL INFORMATION	<p>Delivery: 10 weeks</p> <p>All rugs are handcrafted. Every rug is unique and there may be minor variations in size. Wool is dyed by hand in India and slight chromatic variations between a rug and another may be observed.</p>
MAINTENANCE	<p>Vacuum at least once a week (especially during the first months). In case spill happens, use a sponge to remove as much liquid as possible, then use a lightly diluted detergent. Fully dry the rug with a clean cloth.</p>



MALIKA FAVRE
ORGIE
Rug ●● 2016

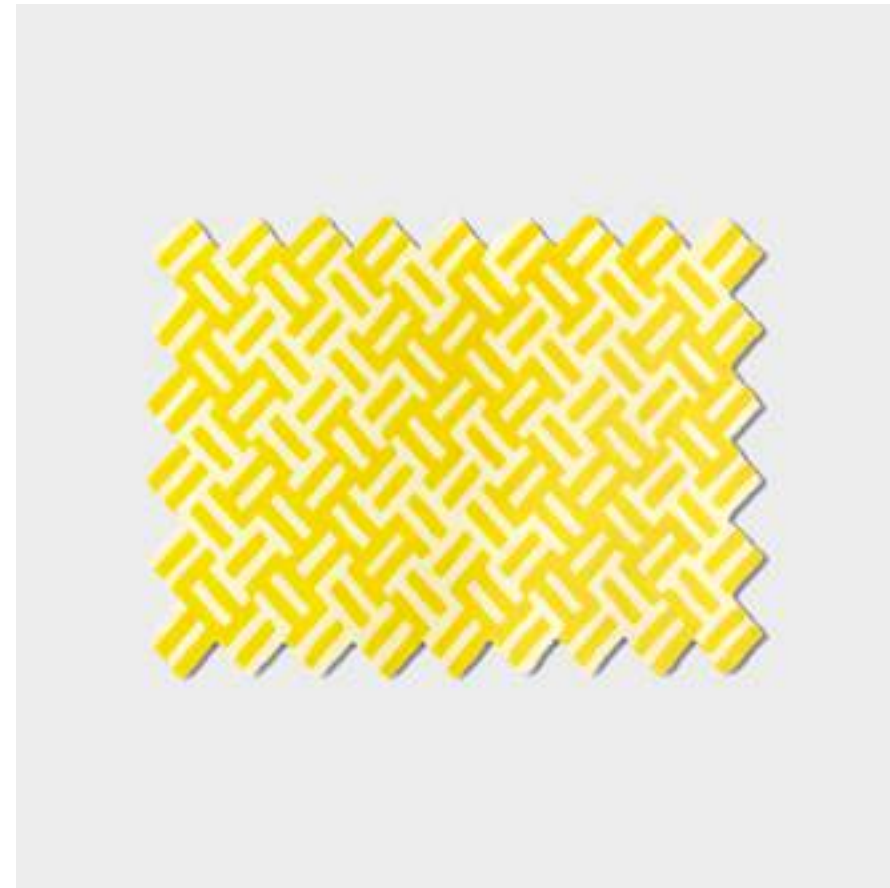

ANATOLE ROYER
CROSS
Rug ●● 2017



MATERIALS & FINISHES

FINISHES

-  Blue and white
-  Black and white
-  Green and white
-  Choose colors available on demand

MATERIALS

100% pure wool,
hand tufted

DIMENSIONS & WEIGHT

	STANDARD	BESPOKE
WIDTH	170cm / 67in.	Color & size can be custom made according to wishes and measurements of the client.
LENGTH	230cm / 90,6in.	
RATIO	W = Lx3/4	

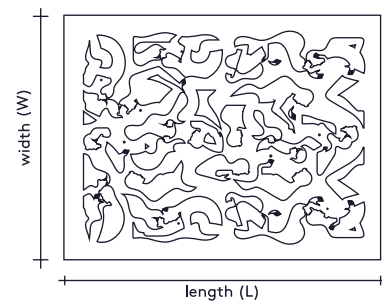



OTHER DETAILS

TECHNICAL INFORMATION	Delivery: 10 weeks All rugs are handcrafted. Every rug is unique and there may be minor variations in size. Wool is dyed by hand in India and slight chromatic variations between a rug and another may be observed.
MAINTENANCE	Vacuum at least once a week (especially during the first months). In case spill happens, use a sponge to remove as much liquid as possible, then use a lightly diluted detergent. Fully dry the rug with a clean cloth.

MATERIALS & FINISHES

FINISHES

-  Red, navy blue, camel and white
-  Black and white
-  Yellow and white

MATERIALS

100% pure wool,
hand tufted

DIMENSIONS & WEIGHT

	CROSS	WITH PACKAGING
WIDTH	Custom made according to the measurements of the client.	Depend on the size chosen.
LENGTH		
WEIGHT		

OTHER DETAILS

TECHNICAL INFORMATION	Delivery: 10 weeks All rugs are handcrafted. Every rug is unique and there may be minor variations in size. Wool is dyed by hand in India and slight chromatic variations between a rug and another may be observed.
MAINTENANCE	Vacuum at least once a week (especially during the first months). In case spill happens, use a sponge to remove as much liquid as possible, then use a lightly diluted detergent. Fully dry the rug with a clean cloth.

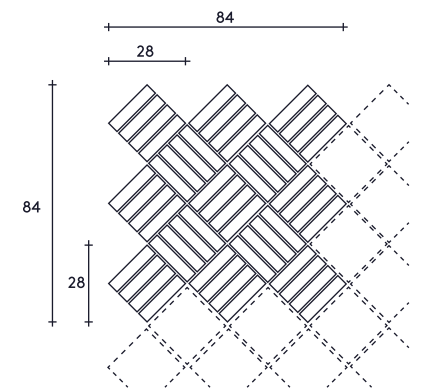

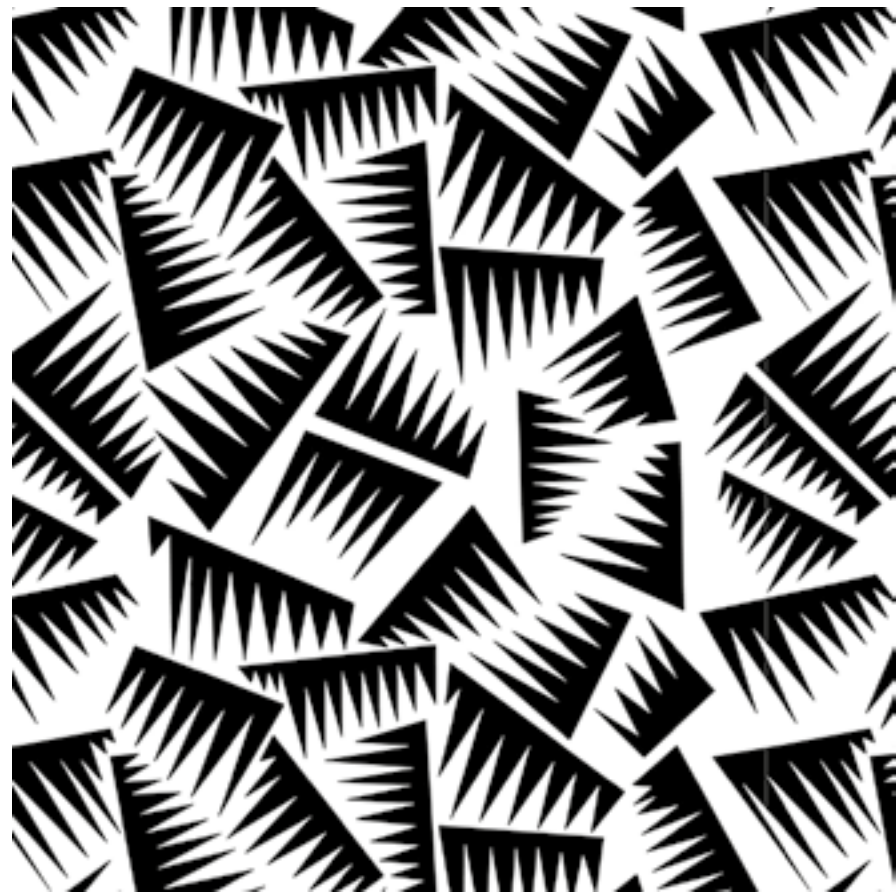

JACQUES-EMILE RUHLMANN

JER

Wallpaper ●● 2016

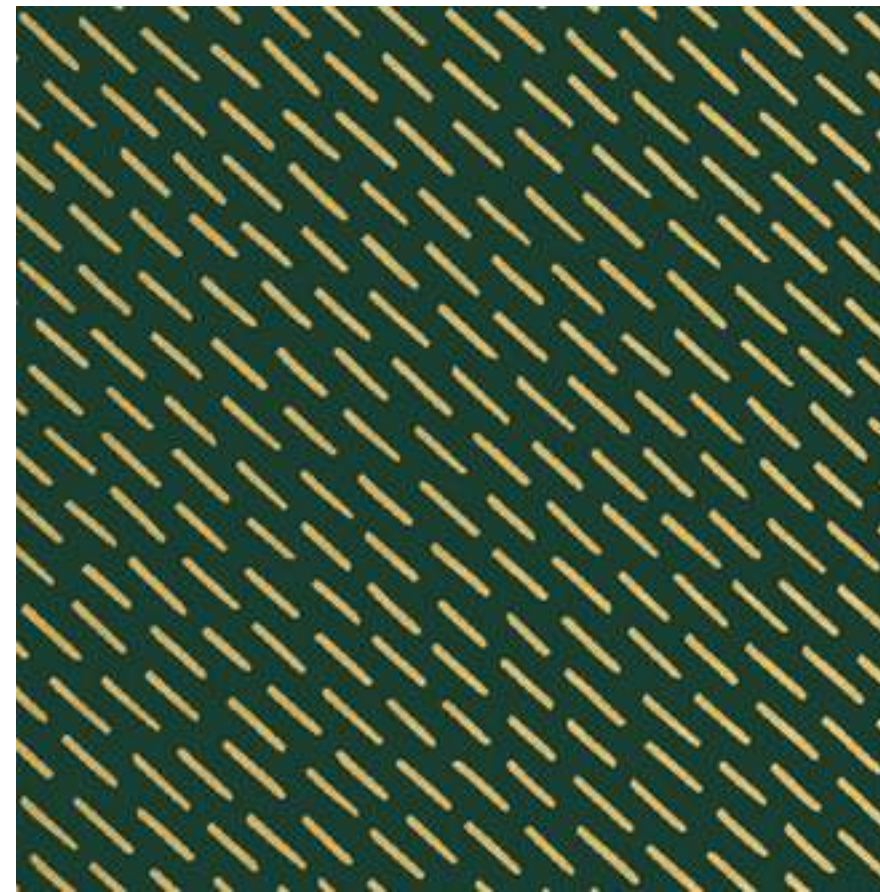
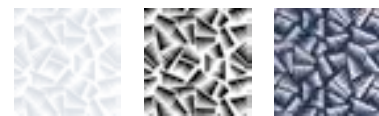

MARTA BAKOWSKI

HAPPY RAIN

Wallpaper ●● 2017



MATERIALS & FINISHES

FINISHES

-  Silver and white
-  Black and white
-  Blue and silver

MATERIALS

150g non-woven paper

DIMENSIONS & WEIGHT

	JER	WITH PACKAGING
HEIGHT	1000cm / 394in.	Packaging size depending on the number of wallpapers.
WIDTH	53cm / 20,9in.	
PATTERN REPEATS DIAMETER	40,38cm / 15,9in. 6cm / 2,5in.	
WEIGHT	0,5kg / 1lbs. (per roll)	

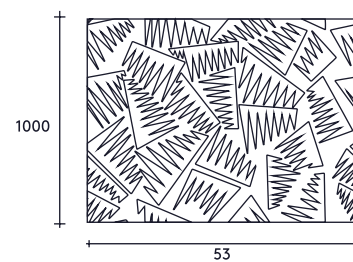





OTHER DETAILS

TECHNICAL INFORMATION	Delivery: in stock Paper quality: 150g
PACKAGING	1 parcel
MAINTENANCE	Non-woven wallpaper, paste the wall only. Never apply any solvents.

MATERIALS & FINISHES

FINISHES

-  Black and white
-  Dark green and gold
-  Sulfur yellow and silver
-  Grey and red

MATERIALS

150g non-woven paper

DIMENSIONS & WEIGHT

	HAPPY RAIN	WITH PACKAGING
HEIGHT	1000cm / 394in.	Packaging size depending on the number of wallpapers.
WIDTH	53cm / 20,9in.	
PATTERN REPEATS DIAMETER	53cm / 20,9in. 6cm / 2,5in.	
WEIGHT	0,5kg / 1lbs. (per roll)	

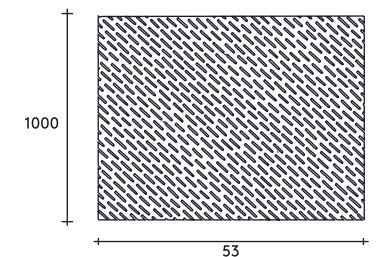

OTHER DETAILS

TECHNICAL INFORMATION	Delivery: in stock Paper quality: 150g
PACKAGING	1 parcel
MAINTENANCE	Non-woven wallpaper, paste the wall only. Never apply any solvents.

Marta Bakowski, Guillaume Delvigne,
Noé Duchaufour Lawrance, François Dumas,
Malika Favre, Alain Gilles, Sebastian Herkner,
Charles Kalpakian, Jonas Lutz, Luca Nichetto,
Note Design Studio, Nathalie Du Pasquier,
Jan Plechac & Henry Wielgus, Pool, Anatole Royer,
Jacques-Emile Ruhlmann, Jean-Baptiste Souletie,
Studio Bling, Jonah Takagi, Tolila & Gilliland,
Bashko Trybek, Frederik Werner & Emil Lagoni Valbak,
Dan Yeffet & Lucie Koldova

Credits

Photography : Aude de Cazenove, Aurélien Chavaud,
Felix Forest, Aleksey Mokhov, Alexis Narodetzky,
Stanislas Wolf

Graphic design : Léa Siat, La Chance

Printing : Imprimerie Leclerc

La Chance

4, rue de la Pierre Levée 75011 Paris FRANCE
+33 (0) 9 72 31 12 77 info@lachance.paris
www.lachance.paris



© La Chance 2019

Sculptural pieces for sophisticated interiors
www.lachance.paris

