

elite, TO BE

elite, TO BE

è lo spirito di un viaggio  
attraverso luoghi, materiali,  
attraverso idee, incontri e suggestioni;  
per cercare quello che amiamo,  
per trovare quello che siamo.

elite, TO BE

the spirit of a journey  
through places, materials, through  
ideas, meetings and suggestions;  
to search for what we love,  
to find what we are.

# IL LEGNO MATERIA VIVA

## WOOD IS AN ALIVE MATERIAL

I prodotti di Elite,TO BE in legno massello sono pezzi unici numerati di alto valore composti da pezzi interi, nel caso del legno di suar, o da pezzi di massello di varie larghezze incollati tra loro, nel caso dei legni di rovere e teak.

I legni utilizzati per produrre questi articoli necessitano di una lunga preparazione e vengono sottoposti ad un processo di essiccazione che avviene in atmosfera controllata con un grado di umidità media del 9% ed una tolleranza adeguata.

La loro unicità consiste nella varietà di venature, di colori e di profumi che rendono il prodotto esclusivo. Per questo motivo differenze di tonalità tra le varie parti del mobile non sono da considerarsi difetti, ma caratteristiche naturali e distintive del materiale.

Il legno massello è una materia viva: per tutto il suo ciclo di vita interagisce con l'ambiente circostante restando sensibile alle variazioni climatiche, al calore e al grado di umidità dell'aria. Crepe, fessurazioni e altri mutamenti superficiali nel corso del tempo sono conseguenze del naturale assestamento del legno in relazione alle diverse condizioni ambientali e non possono costituire motivo di reclamo.

Per una corretta cura del materiale, bisogna evitare di posizionare i prodotti vicino a fonti dirette di calore come stufe, caminetti, termosifoni o termoconvettori o alla luce diretta del sole ed è necessario mantenere nell'ambiente un'umidità relativa ideale intorno al 50% - 55%.

Nei tavoli in massello incollati in Rovere e Teak si possono verificare differenze di spessore di qualche millimetro tra i vari pezzi che compongono il top dovuti a movimenti naturali tipici del legno massello. Piccole fessurazioni possono essere chiuse con un apposito "stucco a cera" in formato di stick in varie colorazioni facilmente reperibile in commercio o presso i punti vendita autorizzati Elite,TO BE. Si consiglia di usare l'ecostucco monocomponente ad acqua e di seguire attentamente le istruzioni d'uso.

I piani in pezzo unico si ricavano da tronchi di albero interi tagliati a metà, pertanto le dimensioni possono variare rispetto a quelle generiche indicate a listino. Nel caso in cui si necessiti di misure precise, si prega di inoltrare richiesta specifica all'atto dell'ordinazione.

Elite,TO BE products in solid wood are unique and numbered items of high value. Those in suar are composed by single entire slates whilst the ones in OAK or in TEAK are made with solid wood pieces glued together.

The woods used to produce these items need a long preparation and drying process. This drying process is made under a strict control with a relative average humidity of 9% with a suitable tolerance.

Their uniqueness consists in its unique grains, colours and scents that make the product exclusive. For this reason, tint differences between the various furniture parts are not defects, but naturals and distinctive material's features.

Solid wood is an "alive" raw material: for its entire life cycle it interacts with the surrounding ambience staying sensitive to the atmospheric conditions, to the heat and to the relative humidity level of the air. Cracks, splits and wood changments during the product life are due to the wood adaptation process according to its surrounding atmospheric conditions and cannot constitute reasons to claim.

For a proper material cure, please refrain from putting the solid wood products near to direct heat sources like oven, fireplaces, radiators, heat convectors or to the direct sun light. It is necessary to keep in the room a relative humidity level of 50-55%.

Tables made with different pieces of solid wood glued together like for instance the ones in oak or teak wood, slight differences in thickness of some millimeters between the different pieces and possible cracks are to be considered as the natural typical movements of solid woods. Small splits can be plastered with an appropriate wax wood repair stick that you can easily buy in a paint shop or at the Elite,TO BE partner shops. Elite to be recommend to use the monocomponent plaster on water basis and to follow exactly the instructions for use.

Tables made in one or two single pieces are obtained from entire logs cut in the middle, therefore dimensions can vary from those reported in the pricelist. In case that precise dimensions are mandatory, please transmit relevant inquiry with precise indications and relevant precise order to the commercial department.

## TAVOLI | TABLES

Ala	p.10
Dasar	p.14
Trog	p.16
Noa	p.20
Snack	p.26
Taolin	p.27

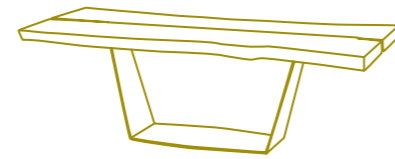

## TAVOLINI | COFFEE TABLES

Al	p.32
Fil de fer	p.34
Kobe	p.36
Otto	p.38
Otto tall   Otto low	p.41
Tris	p.42

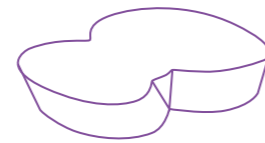

## SEDIE | CHAIRS

Noa	p.50
Kadra	p.52
Kalonga	p.53
Ina	p.54
Tina	p.56
Trog	p.58
Byron	p.59
Serena	p.62
Isa e Giuly	p.64
Giulia	p.65



## SGABELLI | STOOLS

Igloo	p.72
Ketil	p.74
Al	p.75
Hug	p.76
Trapiè	p.78
Avo	p.80
Kaalta	p.81



## CONTENITORI | STORAGE UNITS

Stratos	p.86
Selene	p.90
Orion	p.92
Mooie	p.96
Doda	p.98
M24	p.102
Noa	p.103
Napala	p.106
Hakkasan	p.109

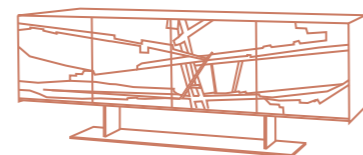

## ILLUMINAZIONE | LIGHTING

Intrigo	p.118
Cappuccini	p.121
Gami	p.122
Ekflamo	p.124
La Lun	p.126
Nest	p.128
Nest midi	p.131
Arboj	p.132
Urban	p.134
Tuli	p.135
Goblet	p.136
Baloon	p.138
Lenti	p.140
Petra	p.141
Radiki	p.142

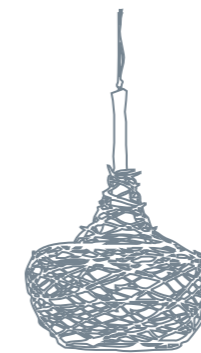

## OGGETTISTICA | ACCESSORIES

The family	p.148
Gong	p.150
Rainbow	p.152
Cardo	p.154
Terno	p.155
Decorazioni murali	p.156



## NOTTE | NIGHT

Noa	p.174
-----	-------

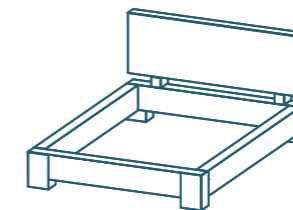

## IMBOTTITI | UPHOLSTERED

Noa	p.180
Age	p.185

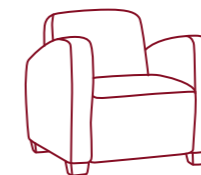

## ENO | ENO-WORLD

La Vit	p.192
Libreria del Vino	p.194





Foto RTI - "Le tre rose di Eva"

TAVOLI | TABLES

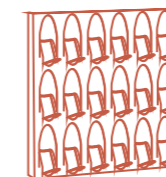
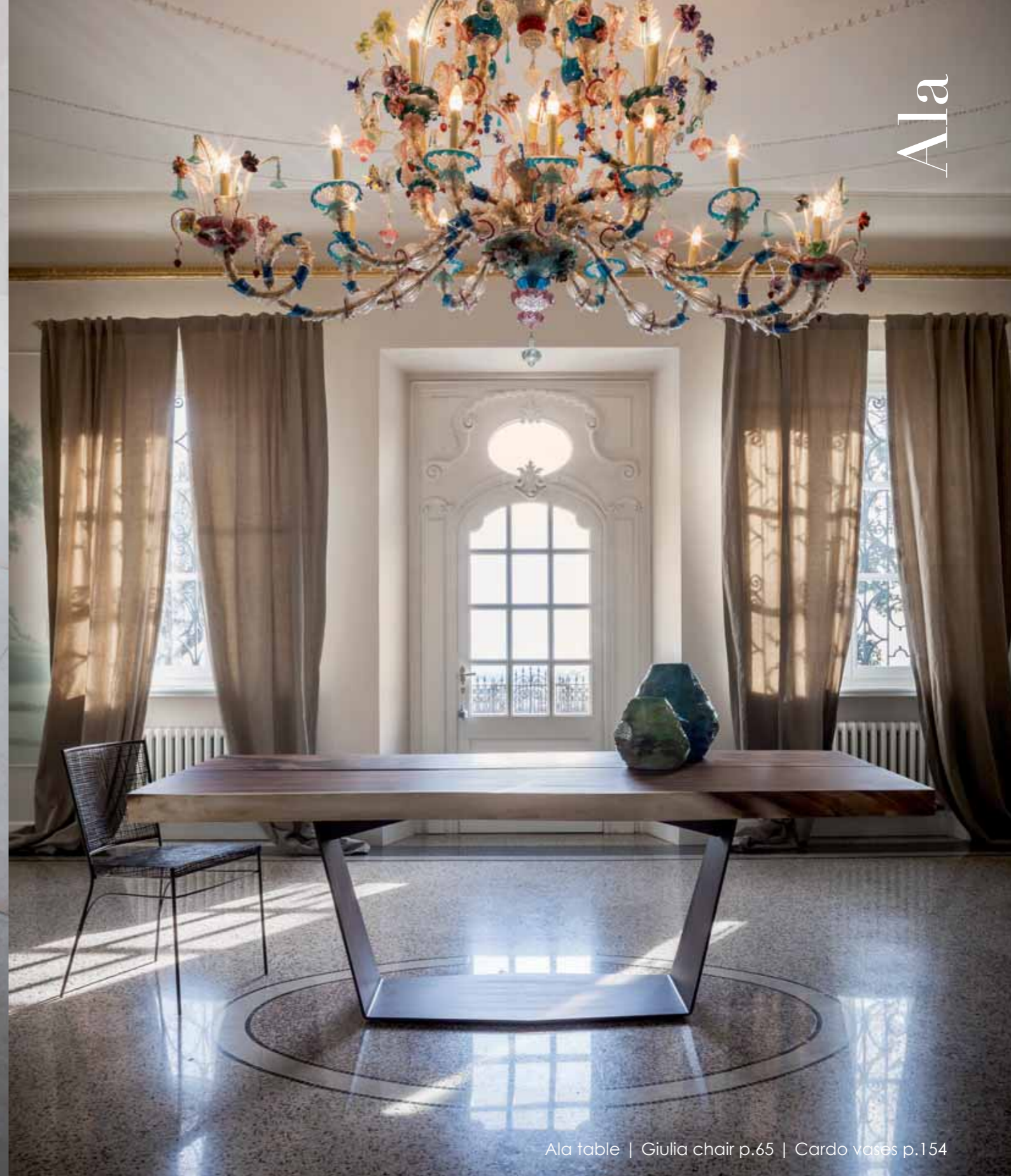

Ala

Ala table | Giulia chair p.65 | Cardo vases p.154



Ala table | Tina chair p.56 | Ketil stools p.74 | Nest midi lamps p.131





# Dasar

Dasar table | Kadra chairs p.52 | Intrigo lamps p.118





Trog table | Ekflamo lamp p.124



Trog



Noa table, chairs p.50 and cabinet p.103 | Al stools p.32-75 | Lenti lamps p.140



Noa table and chair p.50 | Rainbow bowls p. 152





Noa

# Snack



Snack top | Kaalta stool p.81 | Doda storage unit p.98 | Wine bookcase p.194

# Taolin

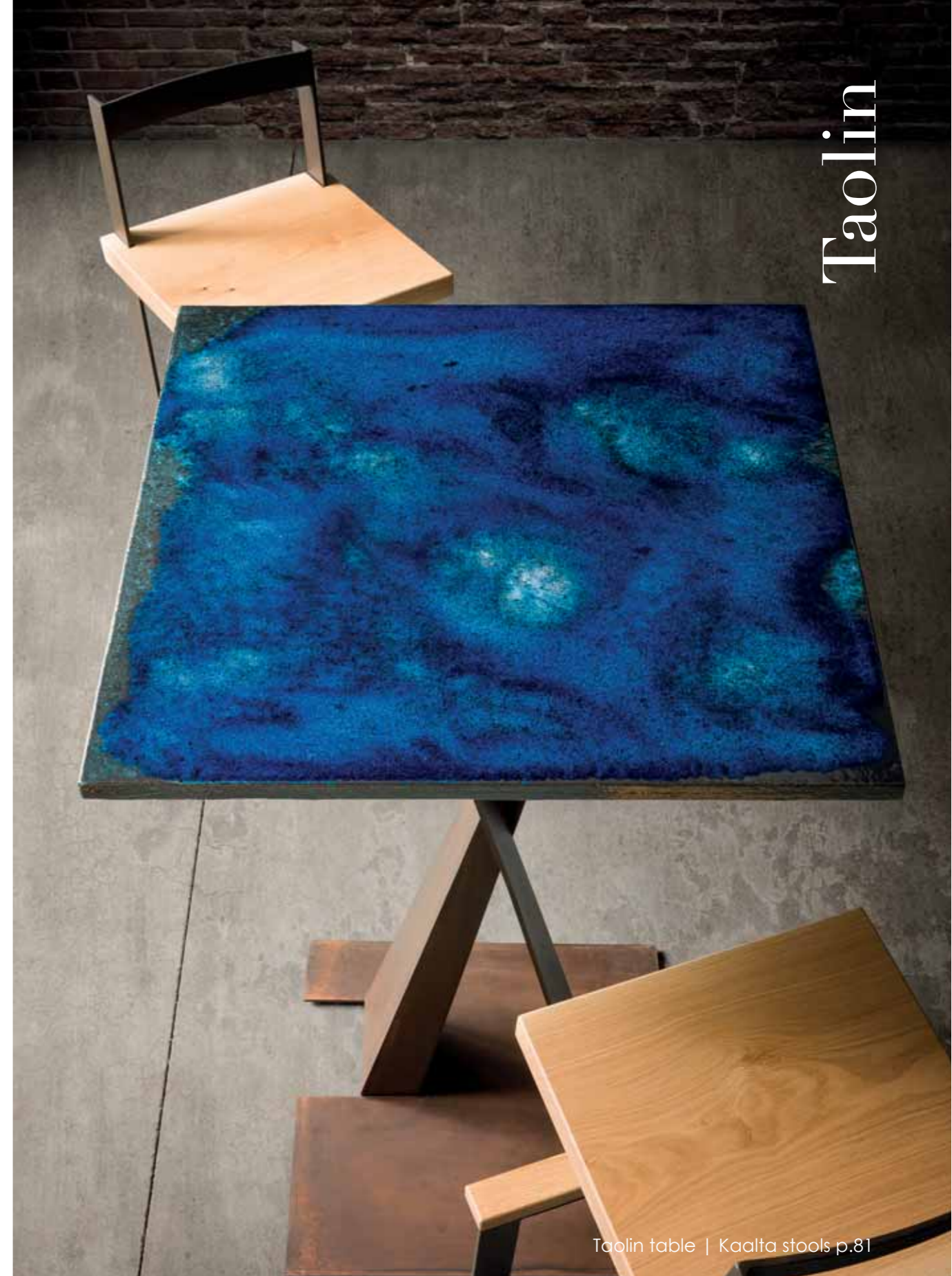

Taolin table | Kaalta stools p.81

## TAVOLI

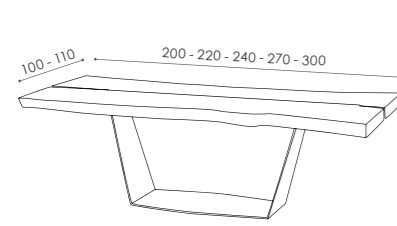

### ALA

Piano tavolo in legno massiccio formato da 2 semipiani in Rovere o Suar, basamento in metallo taglio al laser, nelle seguenti finiture a mano: Corten, Brunito, Bronzato.

*Solid wood table top composted by 2 oak or suar planks. Laser cut iron base in following hand finishes available: corten, burnished and bronze.*

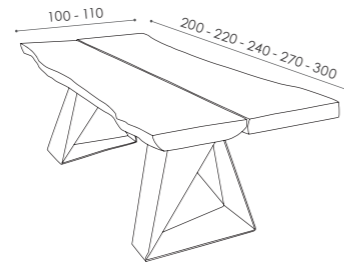

### DASAR

Piano tavolo in legno massiccio formato da 2 semipiani in Rovere o Suar, basamento in metallo taglio al laser, nelle seguenti finiture a mano: Corten, Brunito, Bronzato.

*Solid wood table top composted by 2 oak or suar planks. Laser cut iron base in following hand finishes available: corten, burnished and bronze.*

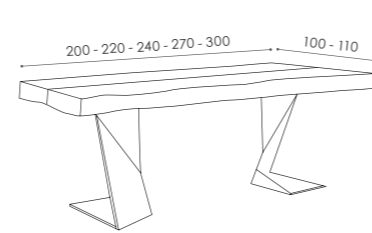
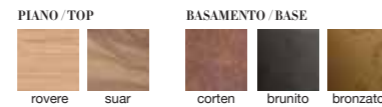

### TROG

Piano tavolo in legno massiccio formato da 2 semipiani in Rovere o Suar, basamento in metallo taglio al laser, nelle seguenti finiture a mano: Corten, Brunito, Bronzato.

*Solid wood table top composted by 2 oak or suar planks. Laser cut iron base in following hand finishes available: corten, burnished and bronze.*



## TAVOLI

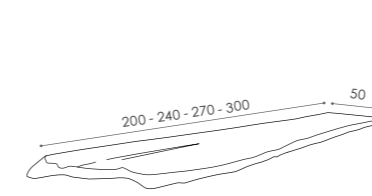

### SNACK

Piano in Rovere o Suar massello, con un lato lungo e testa al naturale, tagliato a 90° gli altri due lati.

*Solid oak or suar top, with one long side and natural on the top. 90° cut on the other two sides.*

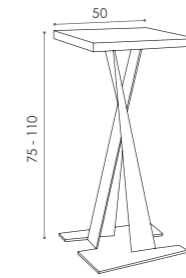

### TAOLIN

Piano in Rovere o Suar massello, base in metallo, taglio laser, finitura manuale in Corten, Brunito e Bronzato.

*Solid oak or suar wood table top and laser-cut iron base with Corten hand finish, burnished or bronze finish.*

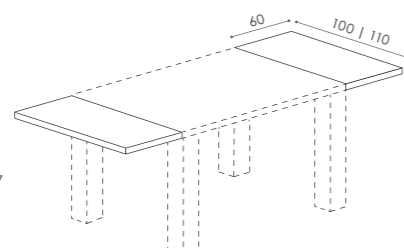
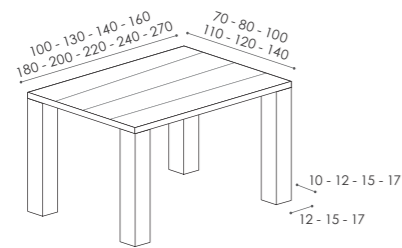
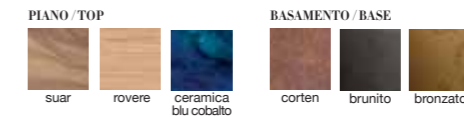

### NOA

Piano tavolo in Teak, Teak riciclato o Rovere massiccio.

*Table top in Teak, Recycled Teak or solid Oak.*

Set gambe in fusione di alluminio o nelle seguenti finiture a mano: Corten, Brunito o Bronzato.

*Set of legs in cast aluminium or available in the following hand finishes: corten, burnished, bronze.*

Allunghe in rovere o teak massiccio, con sistema di fissaggio incorporato (non disponibili in Teak riciclato).

*Table extension in Oak or solid Teak with varnished iron fixing system (recycled teak is not available).*







TAVOLINI | COFFEE TABLES





Kobe stool p.36 | Al stool p.32-75







Otto tall | Otto low







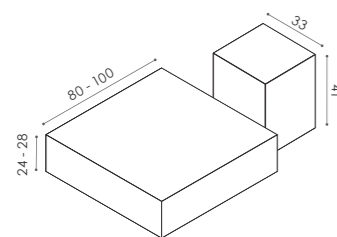

**AL**

Tavolino da caffè e sgabello in fusione di alluminio lucido spazzolato oppure in lamiera con verniciatura a forno tinta Corten, Brunito, Bronzato.

*Coffee table and stool in polished and brushed aluminium or in powder coated iron in following colours: Corten, Burnished and Bronze.*

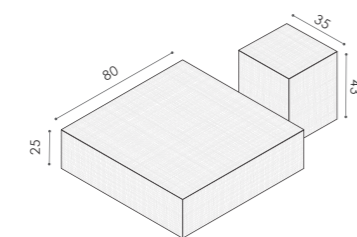
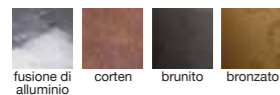

**FIL DE FER**

Tavolo caffè in ferro intrecciato a mano e pressato, verniciato bianco o antracite.

*Coffee table in pressed iron wire, hand braided and varnished in white or anthracite.*

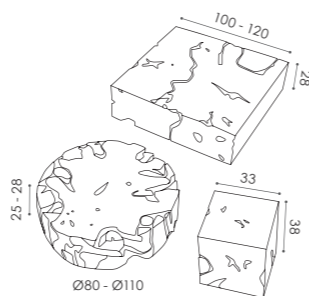
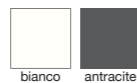

**KOBE**

Tavolino caffè in Radica di Teak levigata e cerata.

*Coffee table in smoothed and waxed solid teak root.*

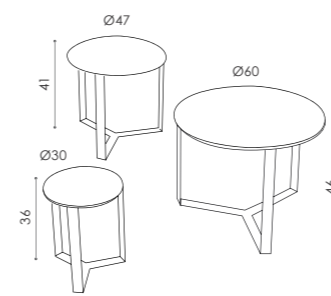

**TRIS**

Set tavolini impilabili lateralmente in metallo taglio laser, finiture fatte a mano: Corten, Brunito e Bronzato. Stessa composizione con tavolino Ø60 decorato in resina atossica incisa. Vendita sul set completo.

*Trio sideways stackable laser cut coffee-table, available in the following finishing: Corten, Burnished and Bronzed. Same composition with Ø60 coffee-table decorated on top with engraved non-toxic resin. Full set only.*

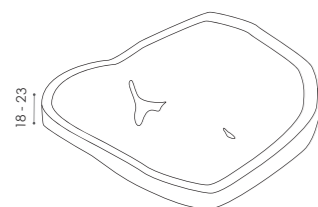
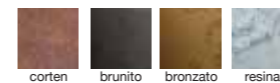

**KROSS**

Tavolo caffè con piano in Suar massello, base in metallo in finitura a mano: Corten, Brunito, Bronzato.

*Coffee table with solid suar wood table top and iron base available in corten, burnished or bronze handfinish.*

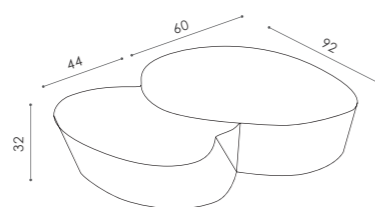

**OTTO**

Tavolino da caffè composto da due pezzi in fusione di alluminio, finitura lucida spazzolata.

*Two part polished and brushed cast aluminium coffee table.*

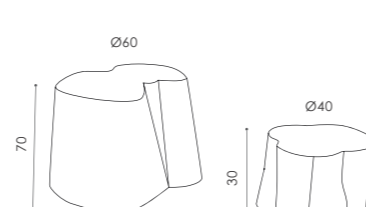

**OTTO LOW E OTTO TALL**

Elementi d'appoggio in fusione di alluminio, finitura lucida spazzolata.

*Polished and brushed cast aluminium coffee tables.*





Noa table p.20 | Noa chairs p.50 | Stratos cabinet p.86 | Igloo stools p.72 | Baloon lamp p.138 |  
Rainbow bowls p.152

SEDIE | CHAIRS



# Kadra



Kadra chairs | Dasar table p.14 | La Lun lamps p.126

# Kalonga



Kalonga bench | Dasar table p.14





Trog

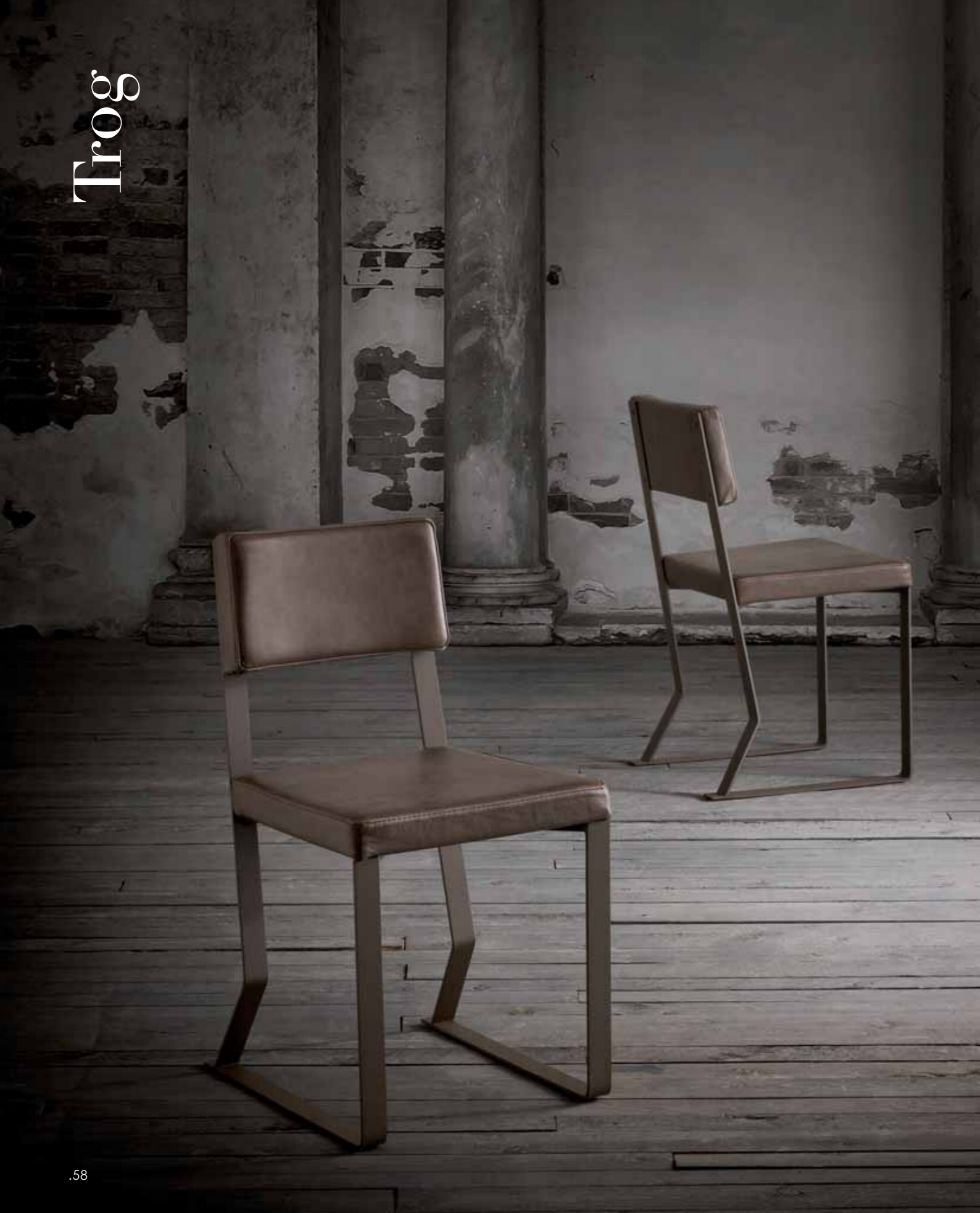

Byron







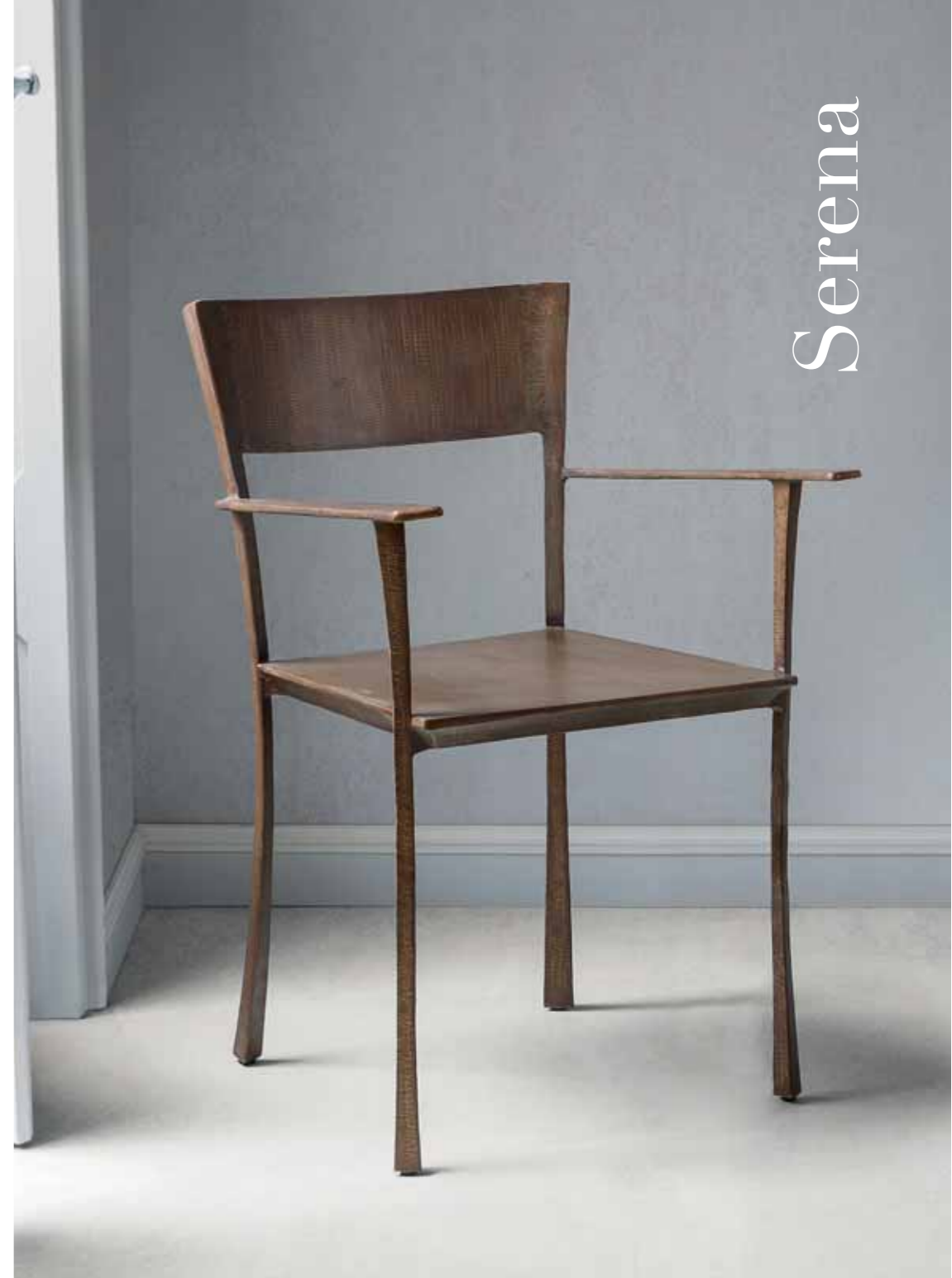

Serena



Giulia



## SEDIE

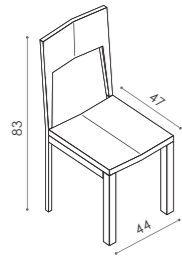

### NOA

Sedia composta da: seduta e gambe anteriori in Teak massello, schienale e gambe posteriori in fusione di alluminio lucidato e spazzolato.

*Chair composed by: seat and front legs in solid Teak, seatback and rear legs in brushed and polished aluminium casting frame.*



teak fusione di alluminio

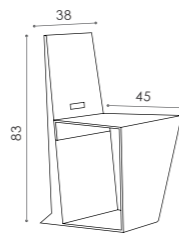

### TINA

Sedia in metallo, taglio laser, in piega con schienale flex, in finitura a mano Brunito e Bronzato.

Verniciatura a polveri nei colori: Rosso, Giallo, Tortora e Corten. *Chair in laser cut folded metal sheet with back part in flex. Burnished or bronzed handfinish. Powder coating available in following colors: red, yellow, taupe and corten.*

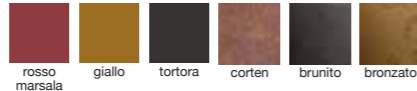

rosso marsala giallo tortora corten brunito bronzato

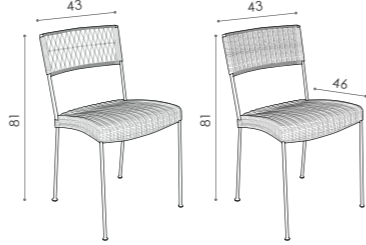

### ISAE GIULY

Sedie in Bambù giovane naturale intrecciato, struttura in tondino di ferro pieno colore antracite. *Chairs in natural hand woven young Bamboo, frame in solid iron rod charcoal grey colour.*

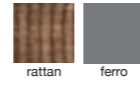

rattan ferro

## SEDIE

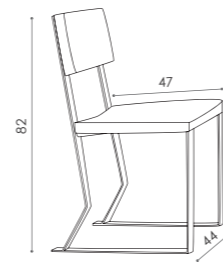

### TROG

Sedia, struttura in ferro taglio laser, finitura a mano in: Corten, Brunito e Bronzato. Seduta e schienali in pelle anticata colore Testa di mora o bianca. Disponibile anche in tessuto. *Chair made of laser cut iron frame available in following handfinishes: Corte, Burnished and Bronzed. Seat and back-chair in antique dark brown leather or white leather. Available also in Fabric.*



SEDTA E SCHIENALE / SEAT AND BACK: pelle bianca, pelle anticata testa di mora. STRUTTURA / FRAME: corten, brunito, bronzato, ottone anticato

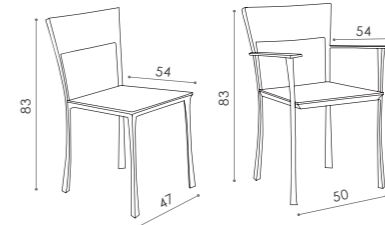

### SERENA

Sedia con struttura in ferro finitura ottone anticato, disponibile con o senza braccioli. *Hand wrought iron chair with or without armrest in antique brass finish.*



ottone anticato

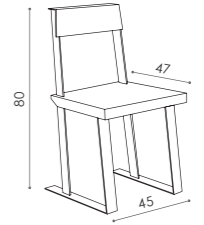

### KADRA

Sedia con struttura in ferro taglio laser, finitura a polveri colore Corten, Brunito e Bronzato. Seduta in legno massello Rovere o Suar. *Chair made of laser cut iron frame available in following handfinishes: Corte, Burnished and Bronzed. Seat and back-chair in Oak or Suar wood.*



SEDTA E SCHIENALE / SEAT AND BACK: rovere, suar. STRUTTURA / FRAME: corten, brunito, bronzato

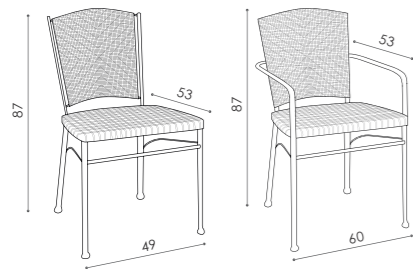

### GIULIA

Sedia con o senza braccioli in filo di ferro nei colori antracite o ruggine, o nella versione in rattan intrecciato color tabacco; struttura in tondino di ferro pieno.

*Chair frame in solid iron rod with or without armrest, seat and backrest in braided iron wire in charcoal grey or rust colour. Braided rattan version in tobacco colour.*



rattan tabacco rattan antracite ferro antracite ferro ruggine

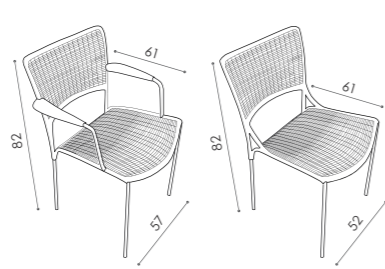

### INA

Sedia con e senza braccioli, struttura in tondino di ferro pieno, seduta e schienale intrecciati a mano in Bambù giovane al naturale.

*Chair frame in solid iron rod with or without armrest, seat and back in braided young bamboo, natural finish.*

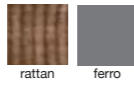

rattan ferro



### BAYRON

Sedia completamente in fusione di alluminio disponibile in finitura lucida o spazzolata opaco. *Monolith cast aluminum chair, available polished or mat brushed finish.*



fusione di alluminio alluminio satinato

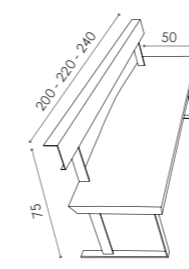

### KALONGA

Panca con struttura in ferro taglio laser, finitura verniciatura a polveri colore Corten, Brunito e Bronzato. Seduta in legno massello Rovere o Suar. *Bench with laser cut iron frame, powder coated in corten, burnished and bronze color available. Solid oak or suar wooden seat.*



SEDTA E SCHIENALE / SEAT AND BACK: rovere, suar. STRUTTURA / FRAME: corten, brunito, bronzato



SGABELLI | STOOLS



Ketil



Al





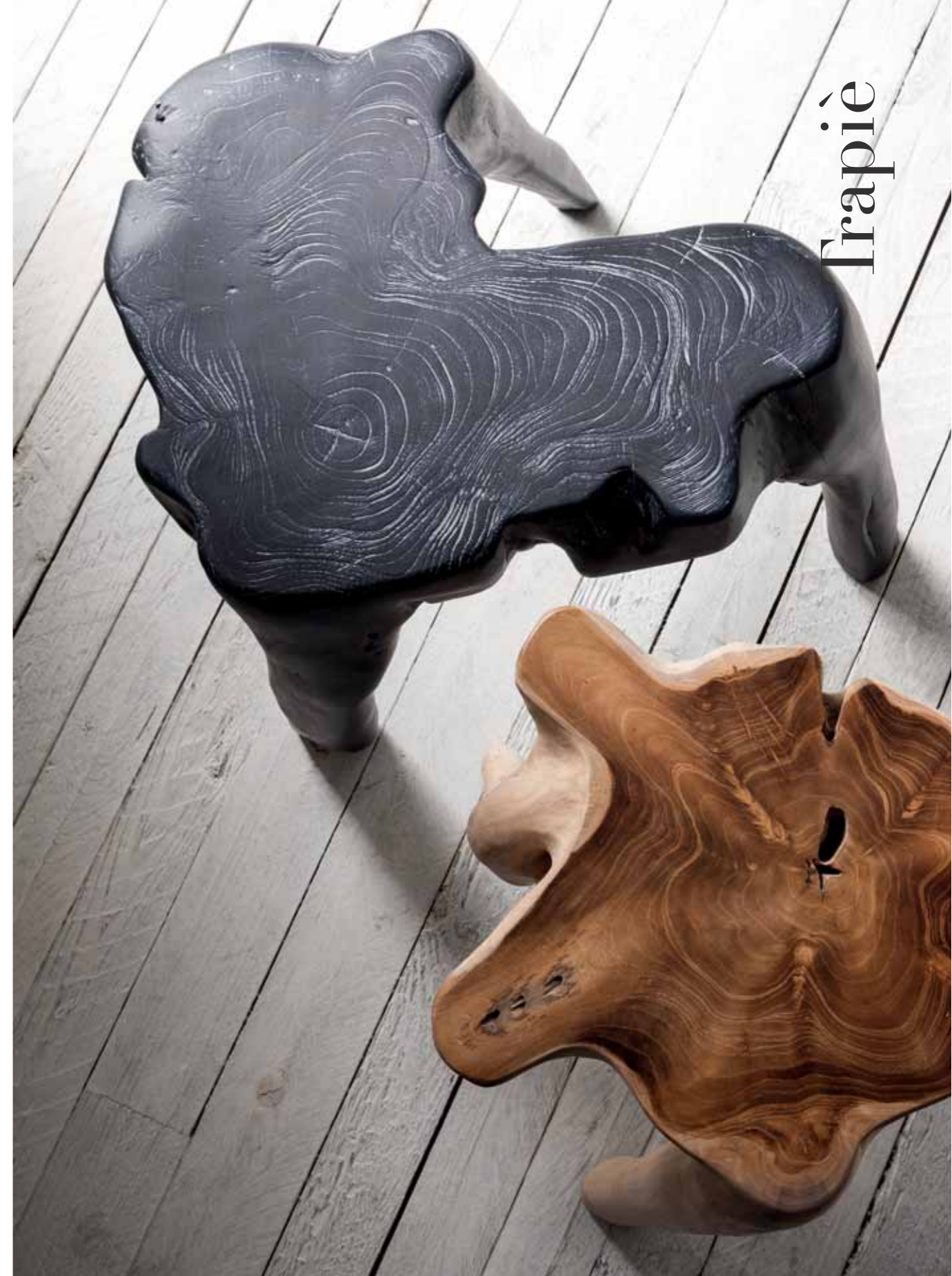

Frapie

Avo



Kaalta

## SGABELLI

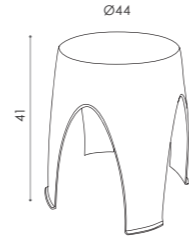
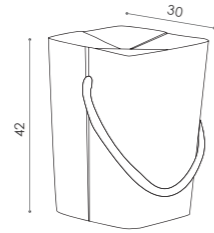
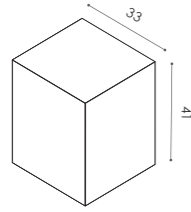

### AL

Sgabello in fusione di alluminio spazzolato lucido o satinato. In lamiera con verniciatura a forno tinta Corten, Brunito, Bronzato. *Cast aluminium stool available in glossy or glazed finishing. Iron sheet powdercoated in corten, burnished and bronze.*

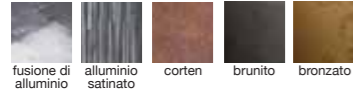

### HUG

Sgabello composto in 4 parti incollate di Abete massello finitura naturale o tinto grigio. Maniglia in corda intrecciata in Bianco, Nero, Canapa, Rosso, Verde Inglese, Blue Navy. *Stool composed by 4 parts of fir wood glued together, available in natural or grey stained finish. Interwoven rope handle in following colours: white, black, hemp, red, english green and navy blue.*



### IGLOO

Sgabello in fusione di alluminio lucido o satinato. *Glossy or glazed cast aluminium stool.*



## SGABELLI

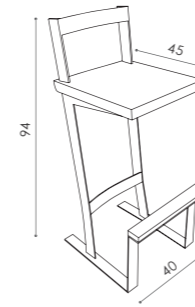

### KAALTA

Sgabello alto, struttura in ferro, con verniciatura a forno colore Corten, Brunito e Bronzato. Seduta e appoggia piedi in Rovere o Suar. *Bar stool with seat and footrest in solid oak or suar wood, iron frame available in corten, burnished or bronze powder coating.*

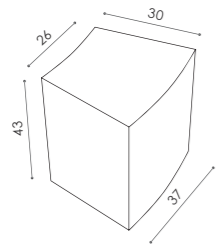

### KETIL

Sgabello a sezione conica in ferro taglio laser, verniciatura a forno colore Corten, Brunito e Bronzato. *Conical stool in laser-cut iron, powder coated in corten, burnished and bronze colour.*

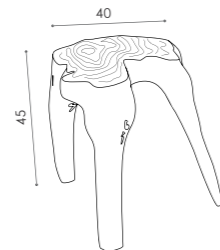

### TRAPIÈ

Radici di Teak o Mogano che vengono ripristinate, carteggiate e lucidate nella parte superiore. *Teak or Mahogany roots, sandpapered and polished on the top.*

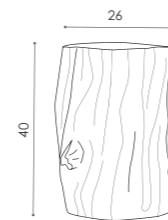

### AVO

Tronco legno massiccio di Quercia estratto da letti di fiume/palude. Eta' stimata : 1500/2000 anni. *Oak wooden Stool, extracted from swamps and river beds. Estimated age: 1500/2000 years.*





Napala storage unit p.106 | Otto coffee table p.38 | Age armchairs p.185 | Arboj lamp.132 | Hug stool p.76

CONTENITORI | STORAGE UNITS



# Stratos



Stratos storage unit - Rainbow bowls p.152





Selene

Selene storage unit | Gami lamps p.122

# Orion



Orion storage unit | Terno mirrors p.155





Mooie storage units p.96 | Hug stools p.76 | Kross coffee table | Age armchairs p.185 | Ekflamo lamps p.124



Mooie

Mooie storage unit | AI stools p.32-75



# Doda



Doda storage units | Ketil stools p.74



M24



Noa



Noa



Noa TV stand | Lenti lamps p.140

Noa



Noa cabinet, Noa chair p.50



Napala

Napala storage unit, Avo stools p.80



Napala storage unit | Al stool p.32-75 | Age armchairs p.185







# Hakkasan

Hakkasan storage unit | Tris coffee tables p.42 | Age armchairs p.185  
Remembering the London beauty wall decoration p.164



Hakkasan storage unit | Age sofa p.185 | Lenti lamps p.140 | Tris coffee tables p.42 | Gong vase p.150 | Fractal in space landscape wall decoration p.156

## MOBILI CONTENITORI

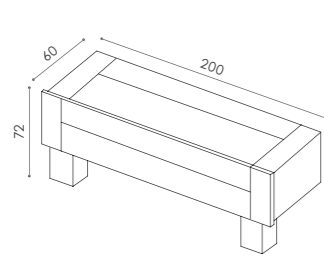

### NOA

Mobile TV in Teak massiccio con frontale unico e 2 cassetti interni in multistrato di pioppo con guide in acciaio inox, **da ancorare tassativamente a parete**, con gambe in fusione di alluminio lucidato. *One drawers chest in solid teak wood, 2 drawers in poplar multilayer inside with stainless steel runners, mandatory to be wall-mounted, legs in polished cast aluminum.*

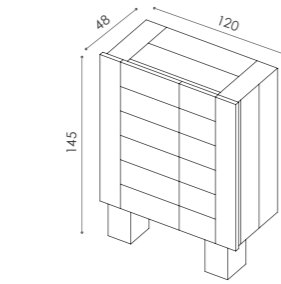

### NOA

Armadio in Teak massiccio a due ante, **da ancorare a parete**, con 2 ripiani interni in teak e gambe in fusione di alluminio lucidato. *Two-door cabinet in solid teak, to be wall-mounted, with 2 internal shelves in teak. Polished and brushed cast aluminum feet.*

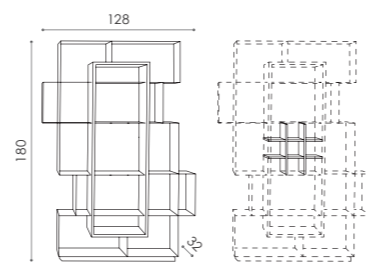

### MOOIE

Contenitore in ferro taglio laser con finitura manuale Corten, Brunito o Bronzato e divisore portabottiglie in Rovere naturale o tinto Wengè. *Laser-cut iron storage unit, with corten, burnished or bronze hand finish and bottle rack divider in natural oak or stained wengé.*

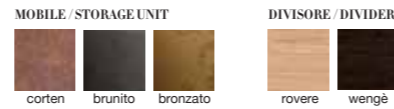

## MOBILI CONTENITORI

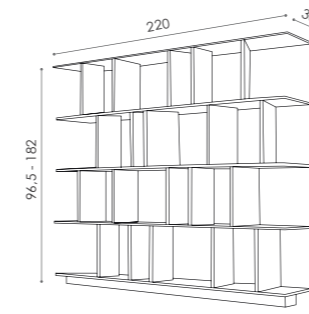

### HAKKASAN

Libreria bifacciale con alzate in teak riciclato girevoli, posizionabili a piacere dal cliente, i ripiani in lamiera con bordi piegata in finitura: Corten, Brunito e Bronzato. *Double face bookshelf with turning recycled teak partitions positionable as you like. The shaped metal sheet shelves available in the following finishing: corten, burnish and bronzed.*



### ORION

Madia a 4 ante, interno impiallacciato Noce Canaletto con ripiani in vetro extrachiaro, ante esterne in ottone acidato con basamento, fianchi e top in ferro tagliato a laser brunito a mano. *4 Door-Sideboard, inside in veneer Walnut "Canaletto" with extra-light tempered glass shelves, doors in oxidized brass, base, sides and top in hand burnished laser cut iron.*

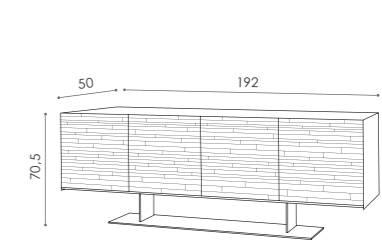

### SELENE

Madia a 4 ante, interno impiallacciato Noce Canaletto con ripiani in vetro extrachiaro, ante esterne in cemento con basamento, fianchi e top in ferro tagliato a laser brunito a mano. *4 Door-Sideboard, inside in veneer Walnut "Canaletto" with extra-light tempered glass shelves, doors in concrete, base, sides and top in hand burnished laser cut iron.*

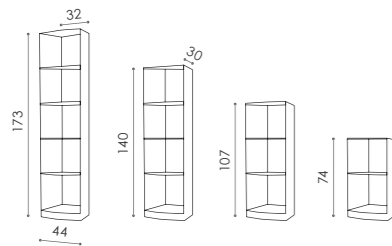
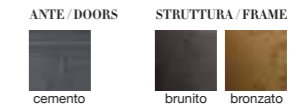

### DODA

Contenitore a giorno, a sezione conica, con piedini regolabili, finitura a mano in Corten, Brunito e Bronzato. Verniciatura a polveri. *Conical bookshelf in laser-cut iron with adjustable feet, with corten, burnished and bronze finish or powder coated.*

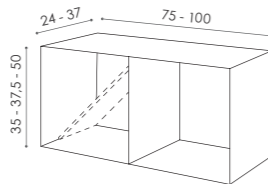

### M24

Contenitore sovrapponibile e pensile in ferro taglio laser con finitura manuale Corten, Brunito o Bronzato o con verniciatura a polveri. Divisore in Rovere naturale. *Laser-cut stackable pensile iron storage unit, with corten, burnished or bronze hand finish or powder coated. Natural oak divider.*

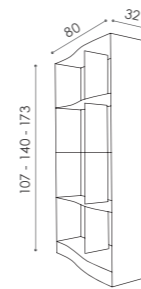

### NAPALA

Contenitore a giorno in ferro taglio laser con curvatura, finitura a mano in corten, brunito o bronzato oppure verniciatura a polveri. *Laser-cut curved iron storage unit with corten, burnished, bronze hand finish or powder coated.*

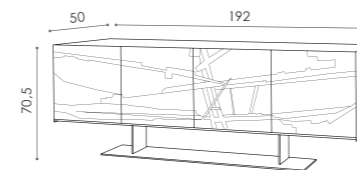

### STRATOS

Madia a 4 ante, interno impiallacciato Noce Canaletto con ripiani in vetro extrachiaro, ante esterne in mosaico composto di pietre, smalto e ceramiche con basamento, fianchi e top in ferro tagliato a laser brunito a mano. *Sideboard with 4 doors, inside in veneer Walnut "Canaletto" with extra-light tempered glass shelves, iron doors coated in stone mosaic, enamel and ceramics. Sides, top and base in hand burnished laser cut iron.*





ILLUMINAZIONE | LIGHTING



# Intrigo



# Cappuccini

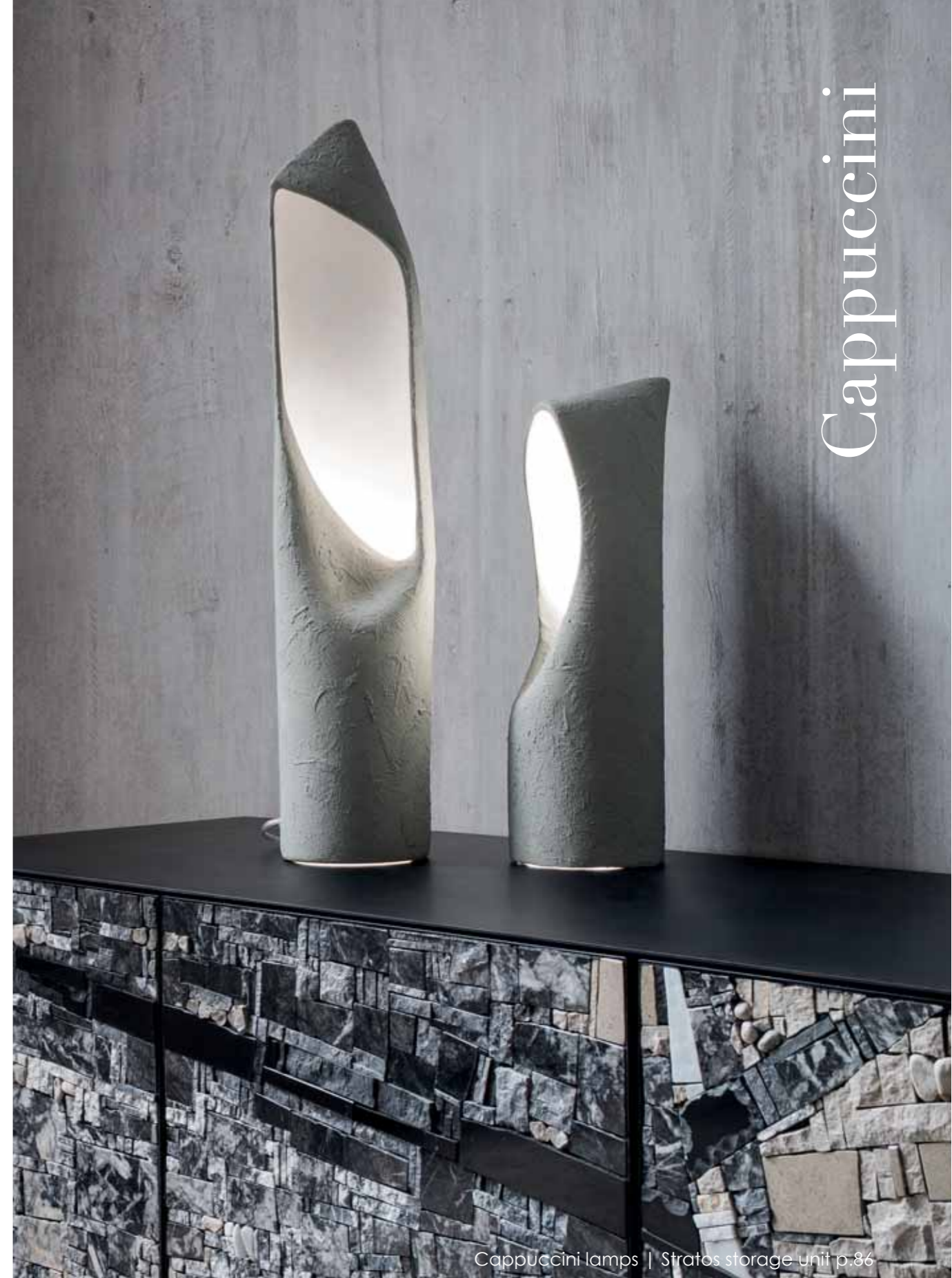

Cappuccini lamps | Stratos storage unit p.86





Ekflamo lamp | Noa sofa p.180 | Al stools p.32-75



Ekflamo

Ekflamo lamp | Trog table p.16



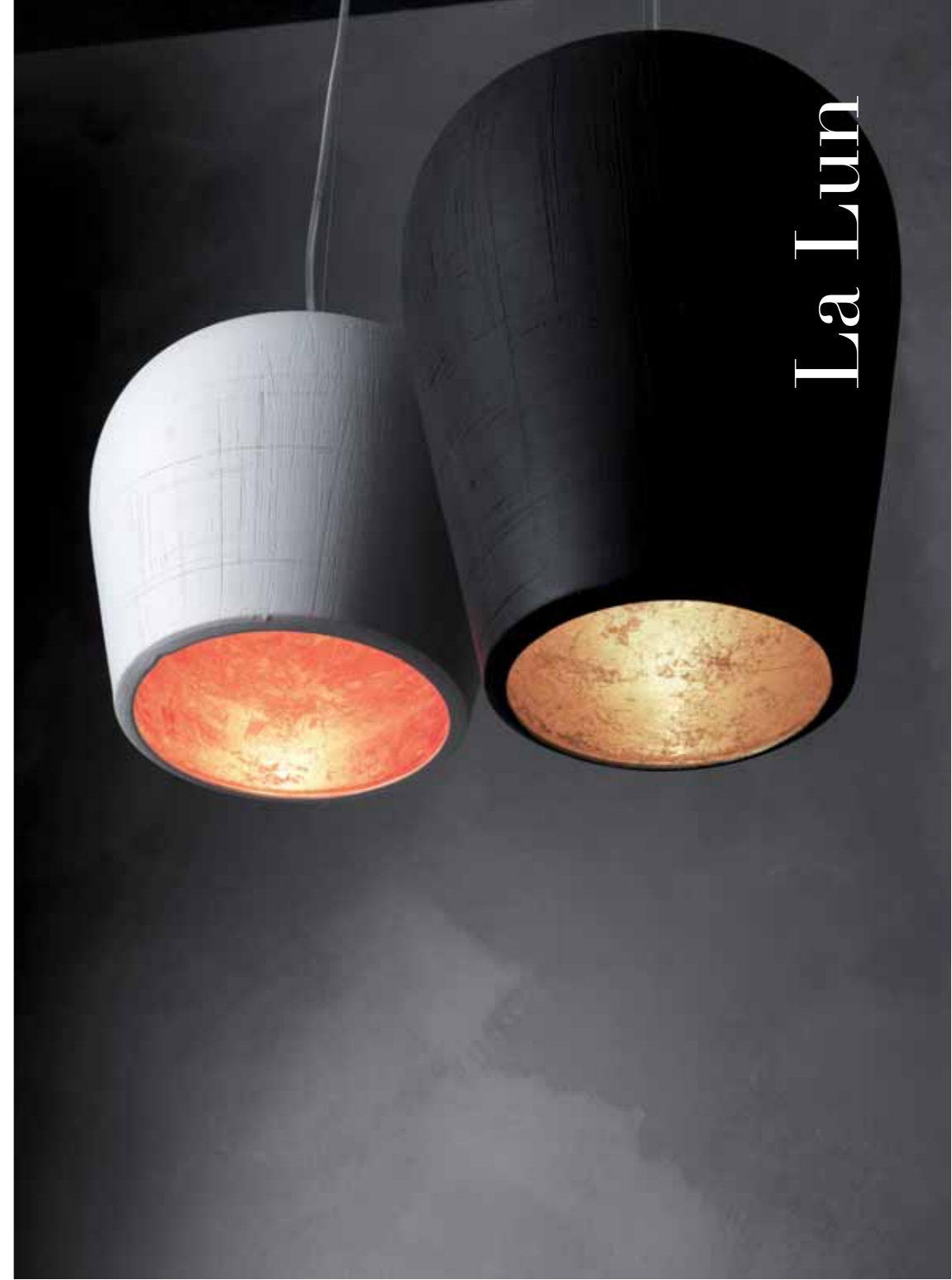

La Lun



Nest



Nest midi

Nest midi lamps | Ala table p.10 | Tina chair p.56 | Ketil stools p.74

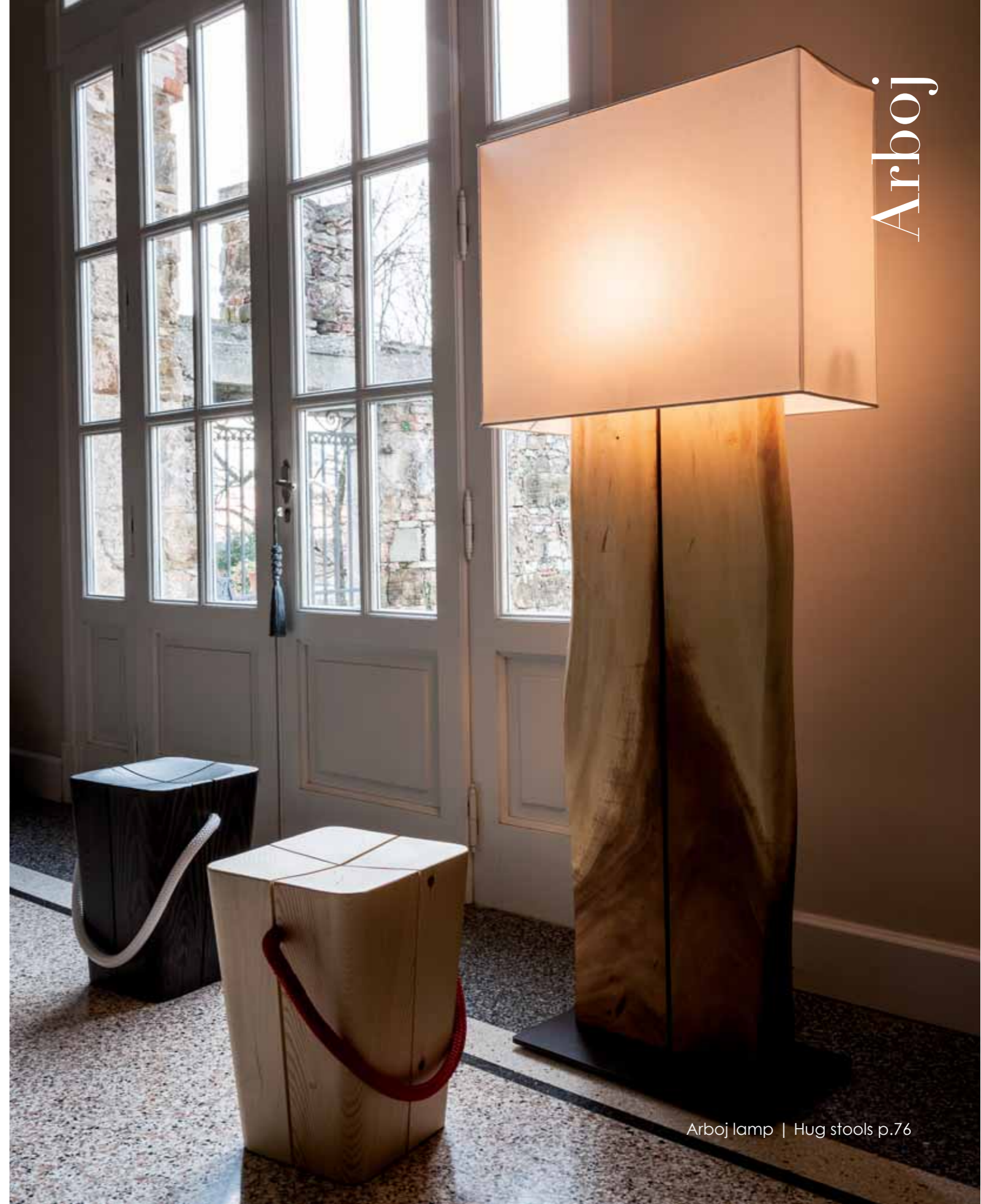

Arboj

Arboj lamp | Hug stools p.76

Urban



Tuli



Tuli lamps | Al coffee table and stools p.32-75

# Goblet



Goblet lamps | Dasar table p.14 | Kadra chairs p.52 | Wine bookcase p.194 | Mooie storage units p.96



Baloon lamp | Noa table p.20 | Stratos cabinet p.86 | Rainbow bowl p.152



Baloon

Lenti



Petra







## ILLUMINAZIONE

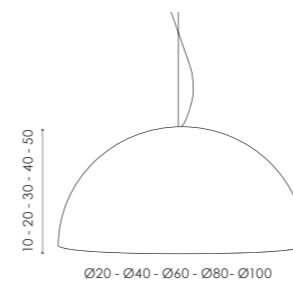

### BALOON

Lampada sospensione con finitura Corten, Brunito e Bronzato esternamente, interno laccato bianco, oppure con interno in foglia Oro e Argento.

*Suspension lamp in Corten, burnished or bronze finish with white internal enamel finish. Available also with internal gold or silver leaf finish.*

#### ESTERNO / EXTERIOR

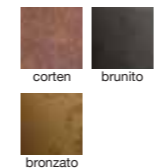

#### INTERNO / INTERIOR

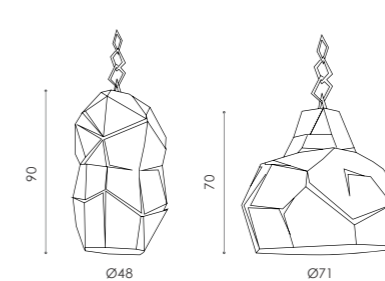

### EKFLAMO

Lampada sospensione in lamiera piegata e saldata, finitura manuale esterna brunito e ottonata interna.

*Suspension lamp composed by welded iron parts, burnished outside handmade finish and brass finish inside. It is available as floor lamp, with relative switch.*

#### ESTERNO / EXTERIOR

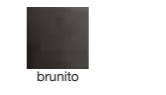

#### INTERNO / INTERIOR

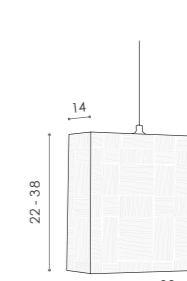
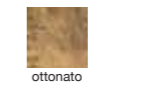

### INTRIGO

Lampada a sospensione in ceramica lucida stracciata nei colori bianco lucido, nero lucido o rame lucido.

*Glossy opaque ceramic suspension lamp with scratching finish.*

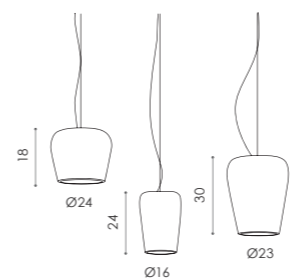
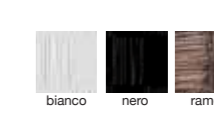

### LALUN

Lampada sospensione in ceramica incisa a mano nei colori: Bianco, Nero, Tortora, Cacao, Sabbia, oppure foglia oro o foglia rame.

*Ceramic suspension lamp with manual scratching in white, black, taupe, coco and sand available, inside gold or copper foil.*

#### ESTERNO / EXTERIOR



#### INTERNO / INTERIOR

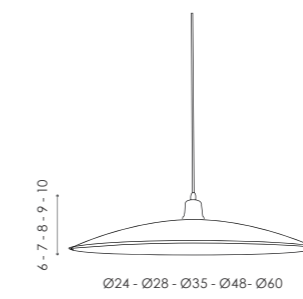

### LENTI

Lampada sospensione in metallo, interno verniciato bianco oppure nei colori bianco, avorio, rosso mosto, azzurro, antracite, nero.

*Iron suspension lamp with varnished white interior, available also in different colours, sizes and finishes.*

#### ESTERNO / EXTERIOR

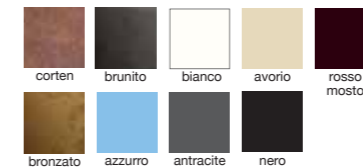

### PETRA

Lampada sospensione in lamiera finitura a mano Corten, Brunito, Bronzato, interno bianco. La lampadina non deve superare i 12 cm di diametro ed i 60 Watt.

*Iron suspension lamp in corten, burnished or bronze hand-finish, inside white. Available in different sizes and finishes. Light bulb should not be larger than 12 cm and not exceed 60 Watt.*

#### ESTERNO / EXTERIOR

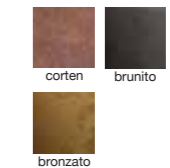

#### INTERNO / INTERIOR



## ILLUMINAZIONE

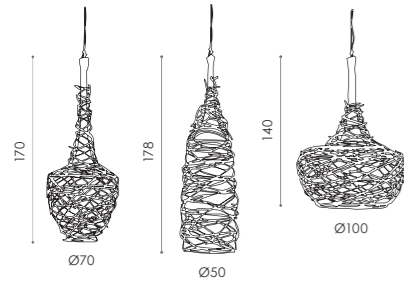

### NEST

Lampade sospensione in tubolare di ferro intrecciate a mano, finitura esterna bronzata e interno ottonato antico.

*Suspension lamp in hand-woven iron tubular, antique bronze finish outside and antique brass finish inside.*



bronzato antico

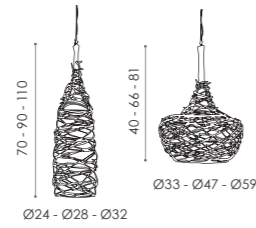

### NEST MIDI

Lampade sospensione in tubolare di ferro intrecciate a mano, finitura esterna bronzata e interno ottonato antico.

*Suspension lamp in hand-woven iron tubular, antique bronze finish outside and antique brass finish inside.*



bronzato antico

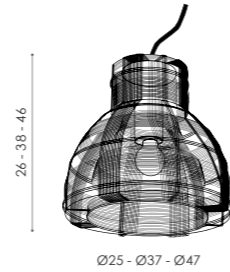

### TULI

Lampada sospensione in Filo di ferro intrecciato in finitura Bianco o Grigio antracite opaco. Disponibile a richiesta in altri colori.

*Braided iron wire suspension lamp, white or charcoal mat. Available upon request in other colours.*

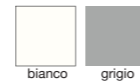

bianco grigio

## ILLUMINAZIONE

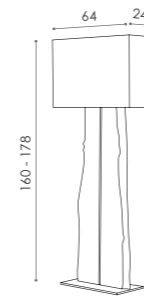

### ARBOJ

Piantana in Rovere e Suar massiccio, basamento in ferro verniciato a forno in Corten, Brunito e Bronzato. Paralume in tessuto. Lamp in solid oak or suar wood and iron base with Corten, burnished or bronze powder coating. Fabric lampshade.

ESTERNO / EXTERIOR



rovere suar

INTERNO / INTERIOR

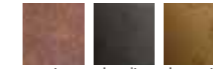

corten brunito bronzato

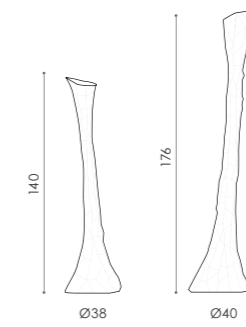

### RADIKI

Piantane in lamiera di ferro piegate e saldate, finitura bronzato scuro. Floor lamp composed by welded iron parts, dark bronze finish.

ESTERNO / EXTERIOR



brunito antico

INTERNO / INTERIOR



ottonato

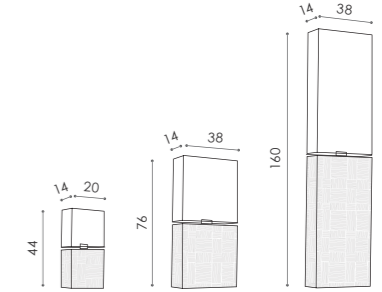

### INTRIGO

Lampada d'appoggio in ceramica lucida stracciata nei colori bianco lucido, nero lucido o rame lucido, paralume in tessuto.

*Glossy opaque ceramic table lamp with scratching finish. Fabric lampshade.*



bianco nero rame

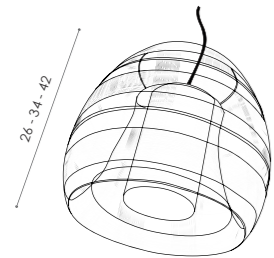

### URBAN

Lampada sospensione in Filo di ferro intrecciato in finitura Bianco o Grigio antracite opaco. Disponibile a richiesta in altri colori.

*Braided iron wire suspension lamp, white or charcoal mat. Available upon request in other colours.*



grigio

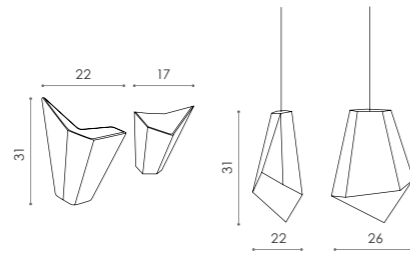

### GAMI

Lampada sospensione o applique in ceramica con finitura cemento esterna e bianco laccato interna, o foglia oro o foglia argento.

*Ceramic suspension lamp in two heights with concrete finish outside and varnished white inside or gold/silver leaf. Available also wall lamp version.*

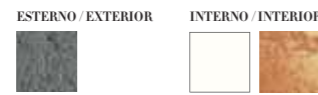

cemento bianco foglia oro

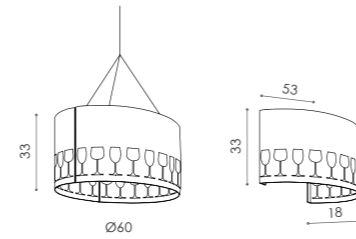

### GOBLET

Lampadario sospensione o applique in lamiera taglio laser con finitura Corten, Brunito e Bronzato.

*Chandelier and wall lamp with Corten, Burnished and Bronze finish. Available also Wall lamp version.*

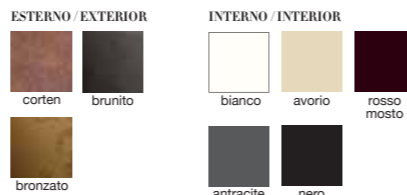

corten brunito bronzato bianco avorio rosso mosto antracite nero

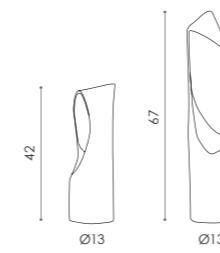

### CAPPUCINI

Lampada d'appoggio in ceramica finitura cemento con interno Bianco lucido.

*Ceramic table lamp, outside in row-cement finish, inside glossy-white.*

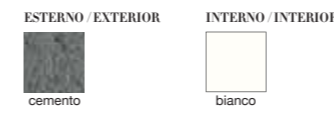

cemento bianco



OGGETTISTICA | ACCESSORIES



The Family coat hanger | Tris coffee tables p.42 | At stool p.32-75



# The family

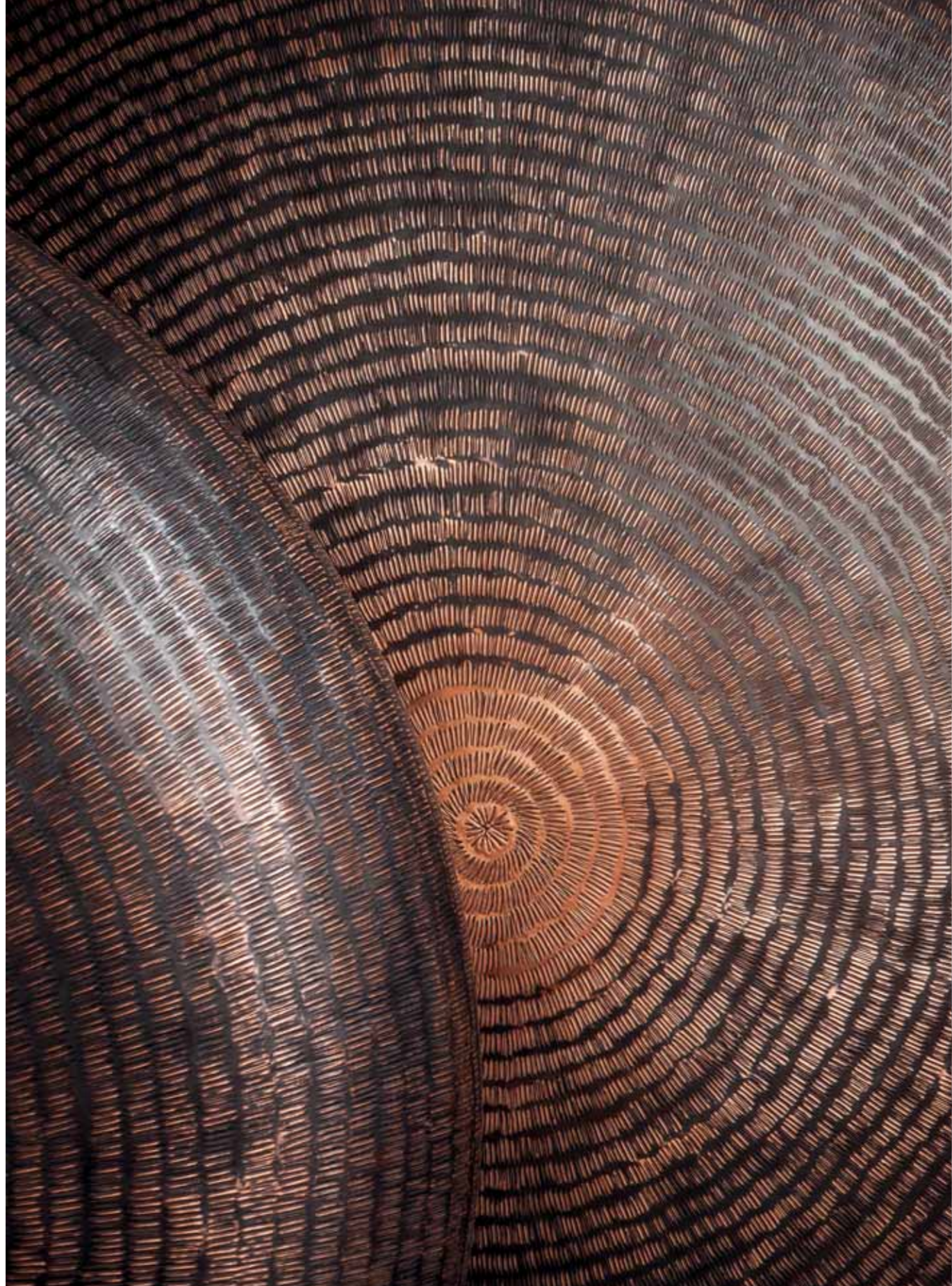

Rainbow



# Cardo



# Terno



# Fractal in space landscape

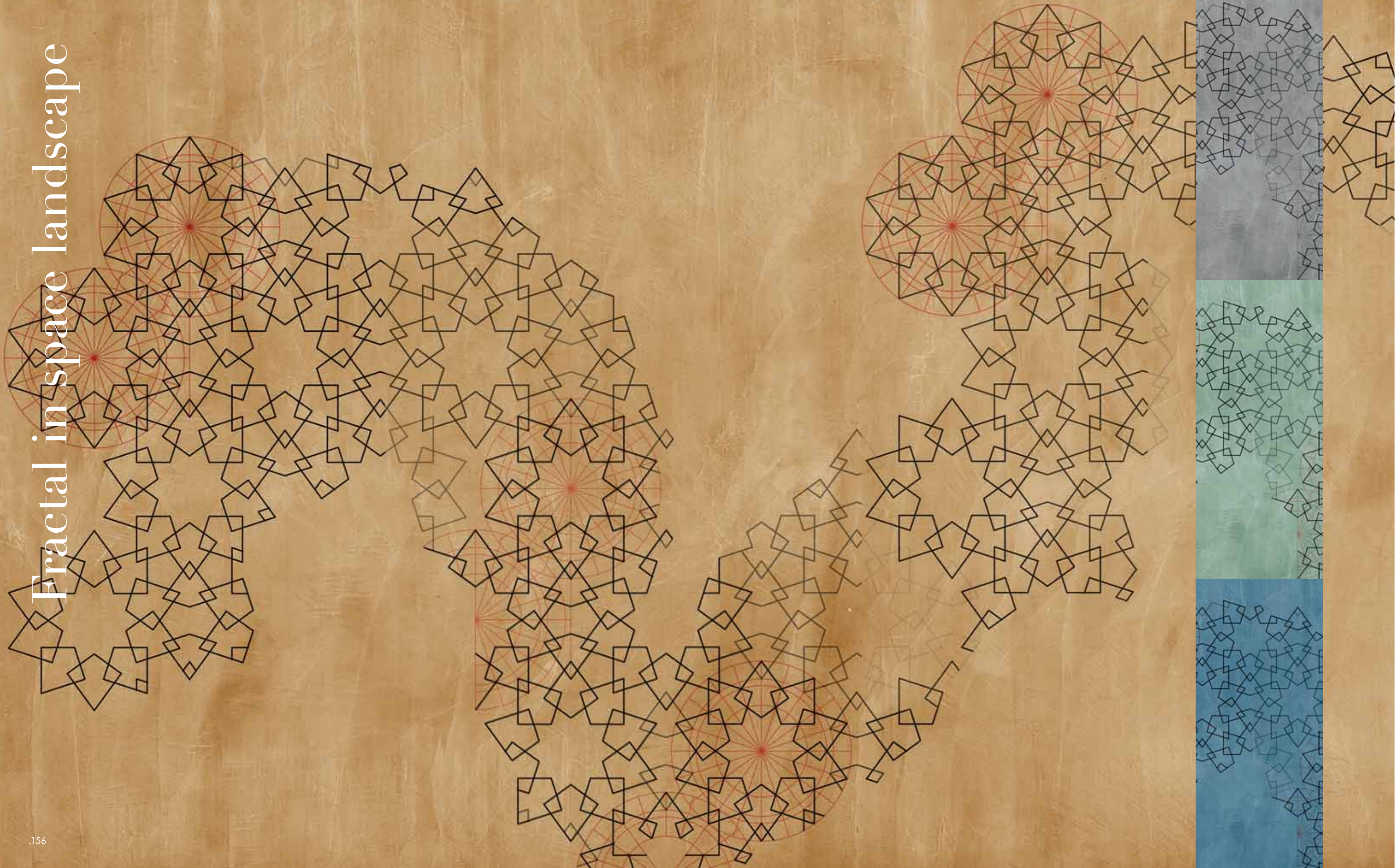



Mexico city wall



# Abstract design variation

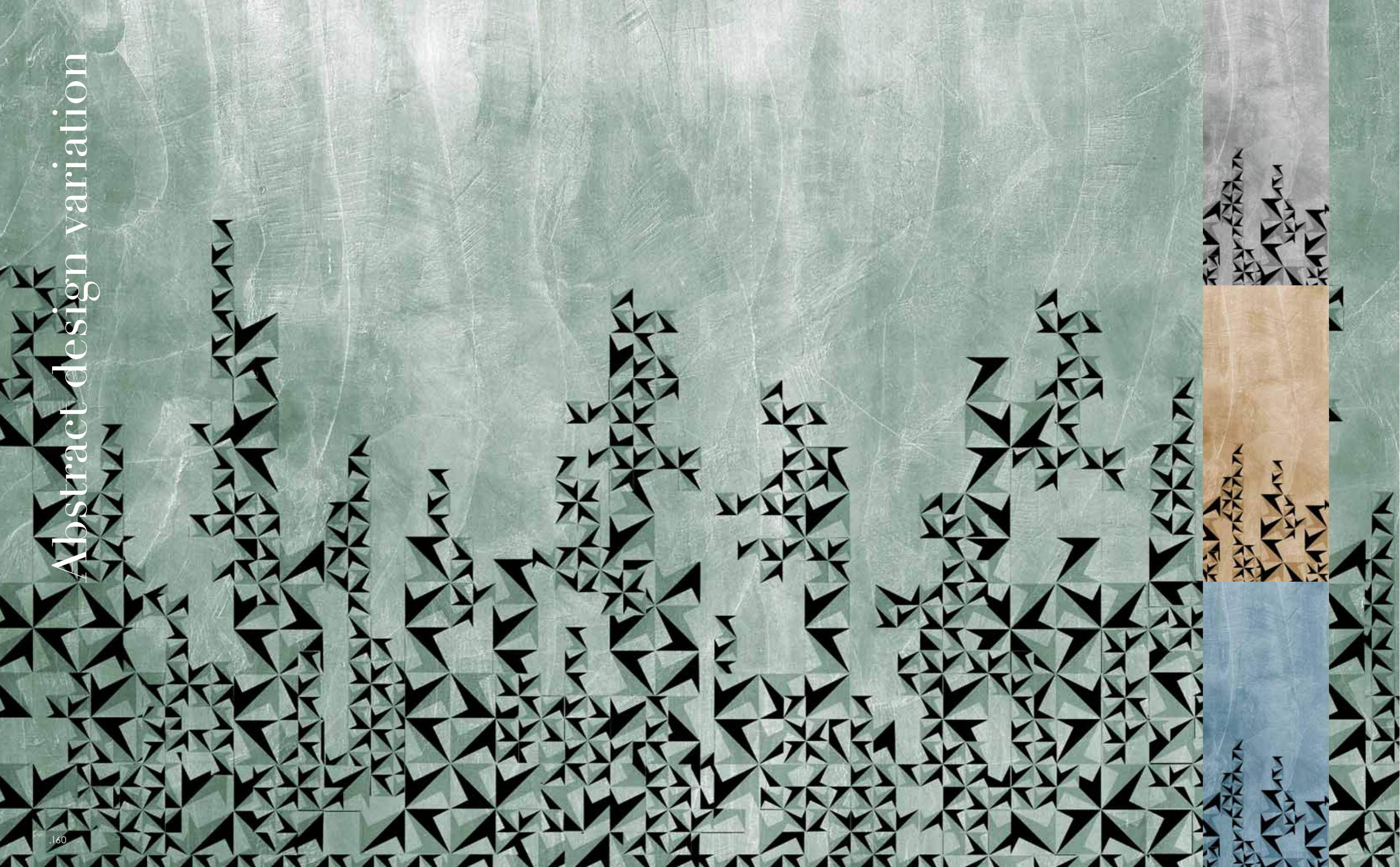

# Spring time in tokyo

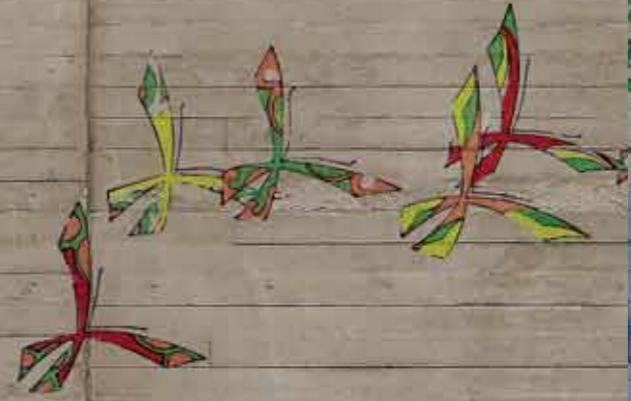
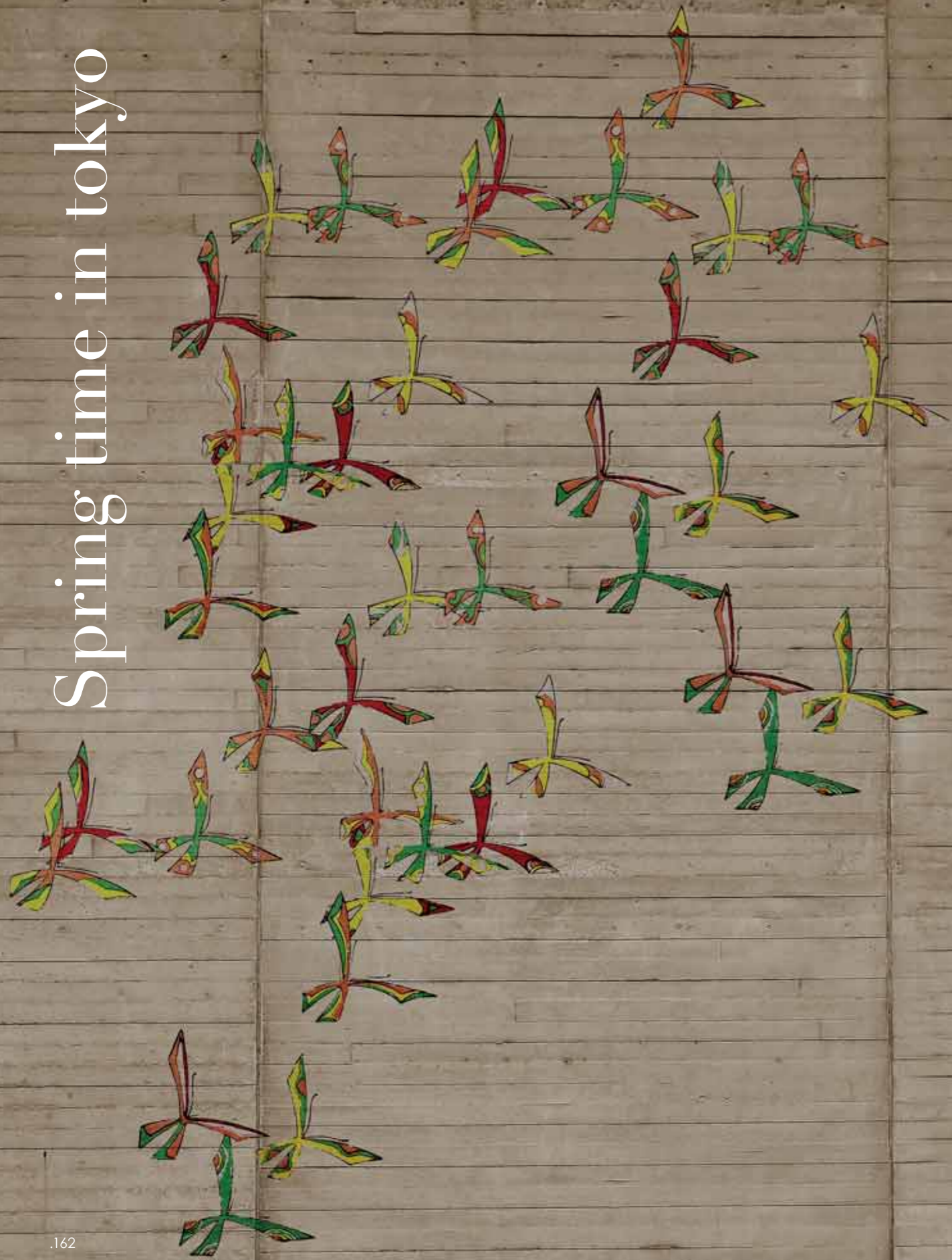

# Remembering the London beauty



# Black orchid in the secret garden



## OGGETTISTICA

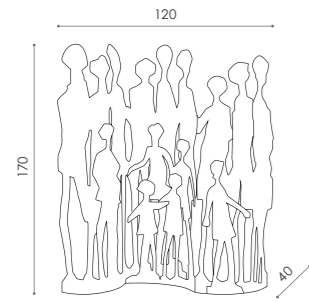

### THE FAMILY

Paravento in lamiera tagliato manualmente con fiamma ossidrica, composto da tre elementi pieghevoli uniti con cerniere fatte a mano. Dipinto solo un lato, altro lato finitura Corten. **Non posizionare all'esterno.**  
Screen composed by three blowpipe cut iron pieces held by handmade hinges in Corten finish. One face painted, other face Corten finish.  
**Not suitable for outdoor use.**



corten

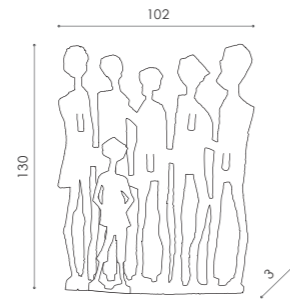

### THE FAMILY

Appendiabiti in lamiera ferro tagliato a cannello e dipinto a mano finitura corten.  
**Non posizionare all'esterno.**  
Coat hanger in blowpipe cut iron, corten finish hand painted.  
**Not suitable for outdoor use.**



corten

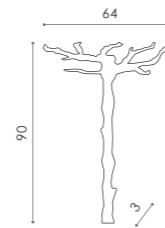

### TREO

Appendiabiti a muro in ferro taglio laser, verniciatura a polveri Corten, Brunito, Bronzato, bianco, antracite o rosso mosto.  
Iron wall-coat hanger, laser-cut, painted in corten, burnished, bronze, white, anthracite or burgundy.

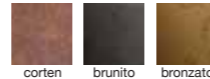

corten

brunito

bronzato



bianco

rosso mosto

antracite

## OGGETTISTICA



### RAINBOW

Ciotole in ceramica con esterno opaco bianco e interno ceramica nei toni: Rosso, Lilla, Verde smeraldo, Blu e Arancio.  
Ceramic bowls, outside white mat finish, inside in the following colours: Red, Purple, Emerald Green, Blue, Orange.

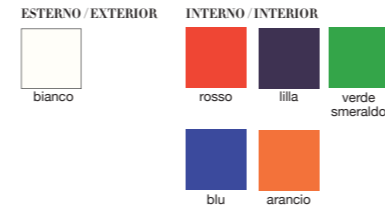

ESTERNO / EXTERIOR



bianco

INTERNO / INTERIOR



rosso



lilla



verde smeraldo



blu



arancio

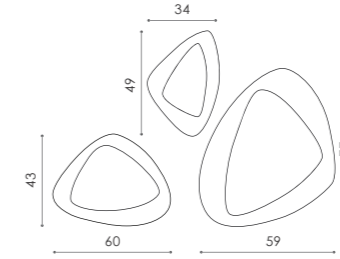

### TERNO

Specchi con cornice in lamiera modellata, la particolare finitura si ottiene con dei passaggi di fiamma ossidrica, che altera il colore del ferro, quindi risultano sempre diversi tra loro.  
Trio mirrors with shaped metal sheet frame. The special finishing is obtained by different steps of blowtorch confers different look from each other altering the metal color.



ferro

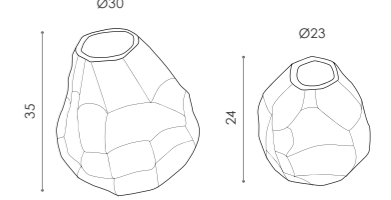

### CARDO

Vasi in ceramica, smalto lucido e carteggiato a mano dove riaffiora il colore originale dell'argilla.  
Ceramic vases in glossy enamel hand sandpapered which enhances the original clay color.



azzurro

verde

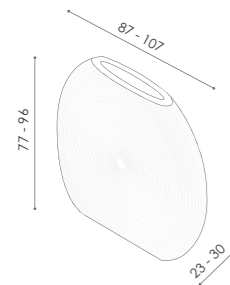

### GONG

Contenitore in Rame interamente battuto a mano, verniciato e spazzolato, NON è Impermeabile, **non mettere acqua internamente.**  
Hand-wrought brass vase. Do not fill with water.



ottone

ottone spazzolato

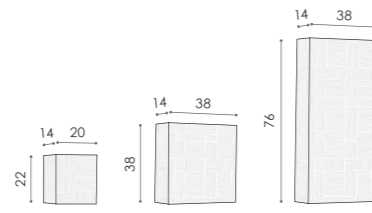

### INTRIGO

Vaso in ceramica con finitura lucida stracciata.  
Ceramic vase with glossy-grooved finish.



bianco

nero

rame

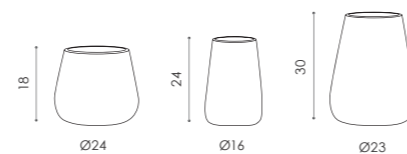

### LALUN

Vaso in ceramica con incisioni esterne fatte a mano nei colori: Bianco, Nero, Tortora, Cacao, Sabbia, Cenere.  
Ceramic vase with manual scratching in white, black, taupe, cocoa, sand and ash colour available.



bianco

sabbia

cacao

cenere

tortora

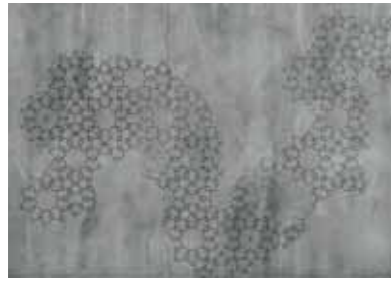

## FRACTAL IN SPACE LANDSCAPE

Carta da parati tessuto non tessuto, con superficie liscia e omogenea, ecocompatibile e certificata FSC.  
*Nonwoven fabric wallpaper, with smooth and homogeneous surface, ecofriendly and FSC certified.*

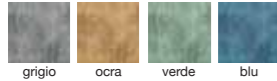

## MEXICO CITY WALL

Carta da parati tessuto non tessuto, con superficie liscia e omogenea, ecocompatibile e certificata FSC.  
*Nonwoven fabric wallpaper, with smooth and homogeneous surface, ecofriendly and FSC certified.*

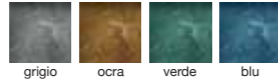

## BLAKOR ORCHID IN THE SECRET GARDEN

Carta da parati tessuto non tessuto, con superficie liscia e omogenea, ecocompatibile e certificata FSC.  
*Nonwoven fabric wallpaper, with smooth and homogeneous surface, ecofriendly and FSC certified.*

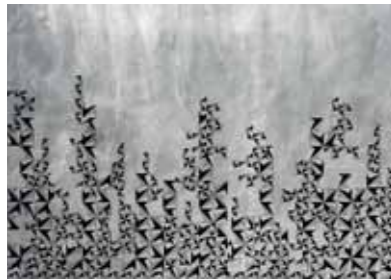

## ABSTRACT DESIGN VARIATION

Carta da parati tessuto non tessuto, con superficie liscia e omogenea, ecocompatibile e certificata FSC.  
*Nonwoven fabric wallpaper, with smooth and homogeneous surface, ecofriendly and FSC certified.*

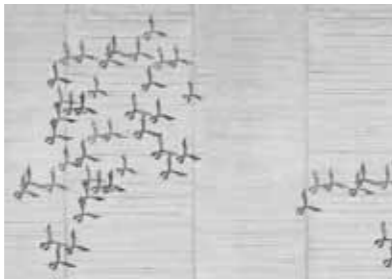

## SPRING TIME IN TOKYO

Carta da parati tessuto non tessuto, con superficie liscia e omogenea, ecocompatibile e certificata FSC.  
*Nonwoven fabric wallpaper, with smooth and homogeneous surface, ecofriendly and FSC certified.*



## REMEMBERING THE LONDON BEAUTY

Carta da parati tessuto non tessuto, con superficie liscia e omogenea, ecocompatibile e certificata FSC.  
*Nonwoven fabric wallpaper, with smooth and homogeneous surface, ecofriendly and FSC certified.*



Noa



Noa bed and night stand | Cappuccini lamps p.121

NOTTE | NIGHT







## NOTTE

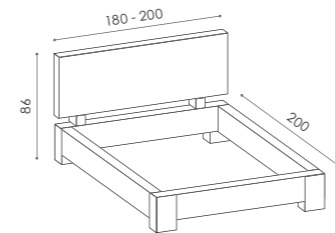

### NOA

Letto in Teak massiccio scatolato con gambe in fusione di alluminio lucidato.  
*Bed in teak wood with polished cast aluminium legs.*

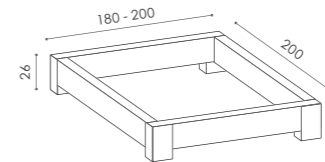

### NOA

Giroletto in Teak massiccio scatolato con gambe in fusione di alluminio lucidato.  
*Bedframe in teak wood with polished cast aluminium legs.*

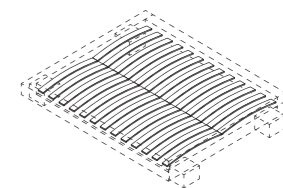

### RETE ORTOPEDICA

Rete ortopedica con doghe in faggio lamellare.  
*Orthopedic bed frame with laminated beech slats.*

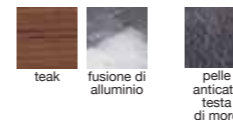

teak fusione di alluminio pelle anticata testa di moro

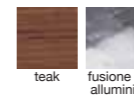

teak fusione di alluminio

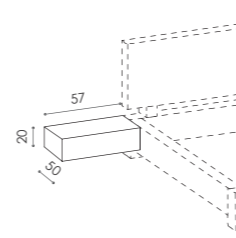

### NOA

Comodino in Teak massiccio con cassetto e guide in alluminio, da ancorare al letto Noa. Non vendibile singolarmente.  
*Beside tables in solid teak wood with drawer and stainless steel runners. Can be fixed to the Noa bed. Not sold separately.*



teak

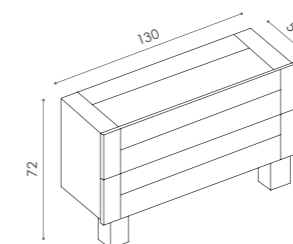

### NOA

Comò con due frontali in Teak massiccio e 4 cassetti interni in multistrato di pioppo con guide in acciaio inox, **da ancorare tassativamente a parete**, con gambe in fusione di alluminio lucido.  
*Two drawers chest in solid teak wood, 4 drawers in poplar multilayer inside with stainless steel runners, **mandatory to be wall-mounted**, legs in polished and brushed cast aluminium.*

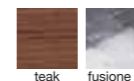

teak fusione di alluminio



Age sofa and armchairs | Otto coffee table p. 38

IMBOTTITI  
UPHOLSTERED



Noa sofa | Al coffee table p.32 | Ekflamo lamp p.124



Noa sofa | Doda storage units p.98 | Hug stool p.76 | Baloon lamps p.138

Noa



Noa sofa with side table | Rainbow bowls p.152

Age



Age armchair | Otto coffee table p.38 | Cardo vase p.154



Foto RTI - "Le tre rose di Eva"



## IMBOTTITI

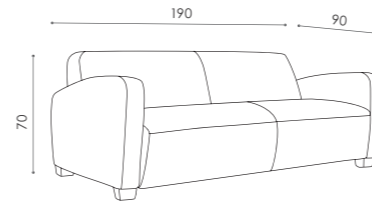

### AGE

Divano con struttura in legno imbottita e rivestita in pelle o tessuto. Imbottitura in poliuretano indeformabile e fibra poliestere. Piedini in legno tinta wengè.  
*Sofa with upholstered wooden frame, covered in leather or fabric. Padding in shape-retaining polyurethane and polyester fibre. Wooden feet in wengè colour.*

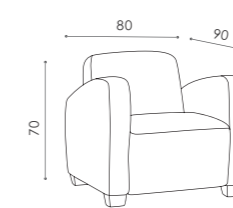

### AGE

Poltrona con struttura in legno imbottita e rivestita in pelle o tessuto. Imbottitura in poliuretano indeformabile e fibra poliestere. Piedini in legno tinta wengè.  
*Armchair with upholstered wooden frame, covered in leather or fabric. Padding in shape-retaining polyurethane and polyester fibre. Wooden feet in wengè colour.*

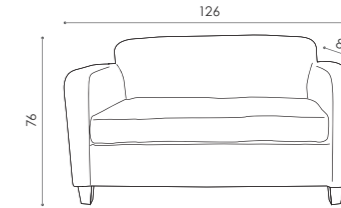

### BUBBLE

Divano con struttura in legno imbottita e rivestita in pelle. Imbottitura in poliuretano indeformabile e fibra poliestere. Piedini in legno tinta wengè.  
*Sofa with upholstered wooden frame, covered in leather. Padding in shape-retaining polyurethane and polyester fibre. Wooden feet in wengè colour.*

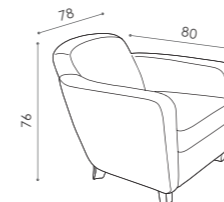
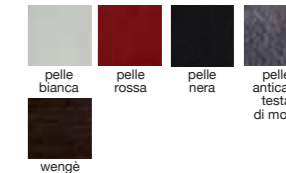

### BUBBLE

Poltrona con struttura in legno imbottita e rivestita in pelle. Imbottitura in poliuretano indeformabile e fibra poliestere. Piedini in legno tinta wengè.  
*Armchair with upholstered wooden frame, covered in leather. Padding in shape-retaining polyurethane and polyester fibre. Wooden feet in wengè colour.*

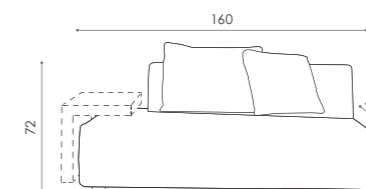
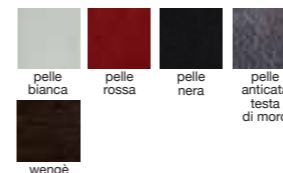

### NOA

Divano con struttura in legno imbottita e rivestita in pelle o tessuto. Imbottitura in poliuretano indeformabile e fibra poliestere. Piedini in legno tinta wengè. Cuscini in piuma d'oca e fibra poliestere.  
*Sofa with upholstered wooden frame, covered in leather or fabric. Padding in shape-retaining polyurethane and polyester fibre. Wooden feet in wengè colour. Cushions in goose down and polyester fibre.*

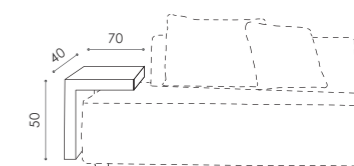

### NOA

Servetto in teak.  
*Side table in teak wood.*











# Libreria del Vino



Wine bookcase | Kaalta stools p.81 | Taolin table p.27









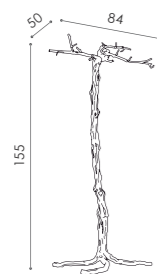

**LAVIT**

Scultura in fusione di alluminio rifinita a mano.  
Cast aluminum handfinished sculpture.



fusione di alluminio

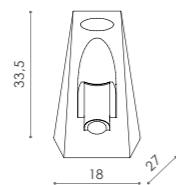

**F1**

Portabottiglie da appoggio per singola bottiglia in lamiera tagliata al laser e ripiegata, con finitura manuale corten, brunito, bronzato.  
Self-supporting single bottle holder support in laser-cut folded tinplate, in corten, burnished or bronze hand finish.

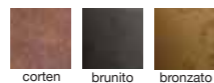

corten brunito bronzato

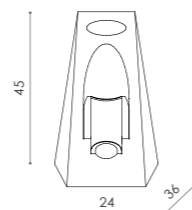

**M1**

Portabottiglie da appoggio per singola bottiglia **magnum** in lamiera tagliata al laser e ripiegata, con finitura manuale corten, brunito, bronzato.  
Self-supporting single magnum bottle holder in laser-cut folded tinplate in corten, burnished or bronze hand finish.

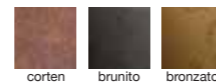

corten brunito bronzato

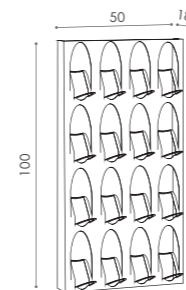

**F16**

Portabottiglie modulare in ferro taglio laser con finitura manuale corten, brunito, bronzato.  
Capienza: 16 bottiglie in verticale.  
Laser-cut iron modular bottle rack in corten, burnished or bronze hand finish. Capacity: 16 bottles in vertical position.

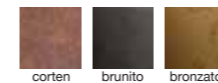

corten brunito bronzato

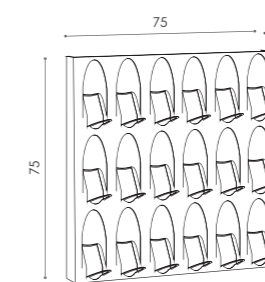

**F18**

Portabottiglie modulare in ferro taglio laser con finitura manuale corten, brunito, bronzato.  
Capienza: 18 bottiglie in verticale.  
Laser-cut iron modular bottle rack in corten, burnished, bronze hand finish. Capacity: 18 bottles in vertical position.

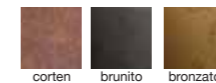

corten brunito bronzato

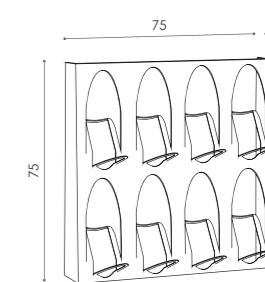

**M8**

Portabottiglie **magnum** modulare, da appendere, in lamiera tagliata al laser e ripiegata, con finitura manuale corten, brunito, bronzato.  
Pensile magnum modular bottle holder in laser-cut folded tinplate in corten, burnished or bronze hand finish.

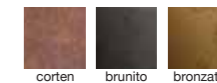

corten brunito bronzato

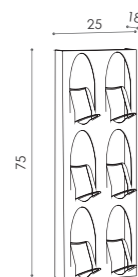

**F6**

Portabottiglie modulare in ferro taglio laser con finitura manuale corten, brunito, bronzato.  
Capienza: 6 bottiglie in verticale.  
Laser-cut iron modular bottle rack with hand finish. Capacity: 6 bottles in vertical position.

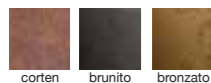

corten brunito bronzato

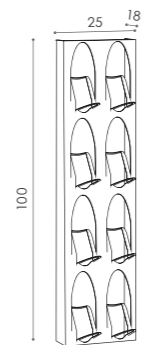

**F8a**

Portabottiglie modulare in ferro taglio laser, con finitura manuale corten, brunito, bronzato.  
Capienza: 8 bottiglie in verticale.  
Laser-cut iron modular bottle rack in corten, burnished or bronze hand finish.  
Capacity: 8 bottles in vertical position.

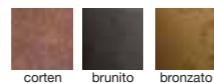

corten brunito bronzato

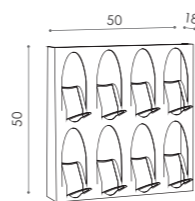

**F8b**

Portabottiglie modulare in ferro taglio laser, con finitura manuale corten, brunito, bronzato.  
Capienza: 8 bottiglie in verticale.  
Laser-cut iron modular bottle rack in corten, burnished or bronze hand finish. Capacity: 8 bottles in vertical position.



corten brunito bronzato

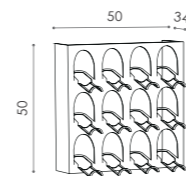

**F12**

Portabottiglie modulare in ferro taglio laser con finitura manuale corten, brunito, bronzato.  
Capienza: 12 bottiglie sdraiate.  
Laser-cut iron modular bottle rack in corten, burnished or bronze hand finish. Capacity: 12 bottles in horizontal position.

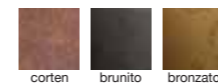

corten brunito bronzato

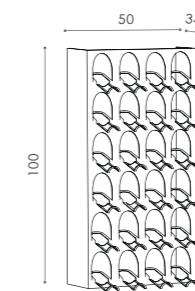

**F24a**

Portabottiglie modulare in ferro taglio laser con finitura manuale corten, brunito, bronzato.  
Capienza: 24 bottiglie sdraiate.  
Laser-cut iron modular bottle rack in corten, burnished or bronze hand finish. Capacity: 24 bottles in horizontal position.

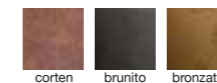

corten brunito bronzato

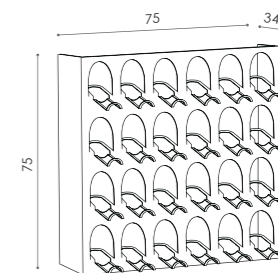

**F24b**

Portabottiglie modulare in ferro taglio laser con finitura manuale corten, brunito, bronzato.  
Capienza: 24 bottiglie sdraiate.  
Laser-cut iron modular bottle rack in corten, burnished, bronze hand finish. Capacity: 24 bottles in horizontal position.



corten brunito bronzato



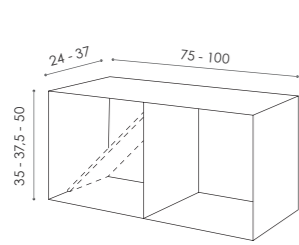

**M24**

Contenitore sovrapponibile e pensile in ferro taglio laser con finitura manuale corten, brunito, bronzato. Divisore in rovere naturale.

*Laser-cut stackable pensile iron storage unit, with corten, burnished or bronze hand finish. Natural oak divider.*

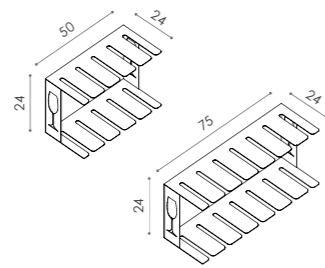
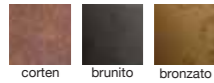

**B24**

Portabicchieri con decorazione a calice in lamiera tagliata al laser e ripiegata, con finitura manuale corten, brunito, bronzato.

*Decorated chalice cup holders in laser-cut folded tinplate, with corten, burnished or bronze hand finish.*

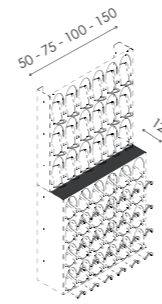
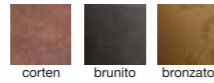

**MENSOLATOP**

Top di finitura in metallo o legno per abbinare moduli di profondità diverse. Finiture in combinazione. *Shelf top in metal or wood finishing to stack different depth modules.*

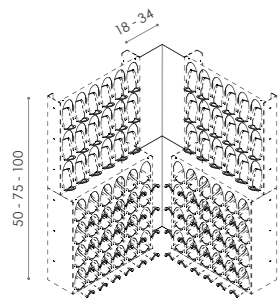
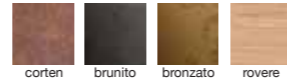

**RACCORDO ANGOLARE**

Fasce di raccordo per composizioni angolari. Finiture in combinazione. *Fixing bands for angular compositions.*

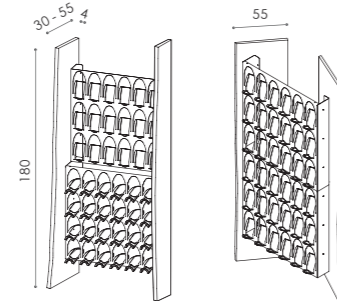
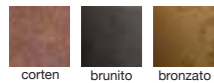

**FIANCHI IN LEGNO**

Coppia di fianchi in rovere o suar massiccio per composizione a parete monofacciale o bifacciale. A richiesta anche in ferro finitura corten o verniciato. *Side panel couple in solid oak or suar wood for single face or double face wall composition. Upon request, the sides are also available in varnished or corten finish iron.*

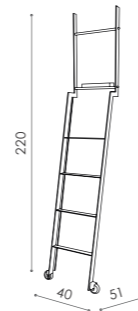

**SCALA**

Scala in ferro con gradini rivestiti in listello di rovere per "Libreria del Vino". *Iron ladder for wine library with oak clad steps.*

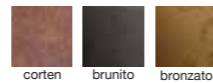

# ESSENZE

WOOD / HOLZ / BOIS



**ROVERE**  
Oak / Eiche / Chêne



**SUAR**  
Suar



**ROVERE VECCHIO**  
Antique Oak / Altes Eichenholz / Chêne antique



**NOCE CANALETTO**  
Walnut "Canaletto" / Nussbaumholz "Canaletto" / Noyer "Canaletto"



**TEAK**  
Teak



**TEAK RICICLATO**  
Recycled teak / Wiederverwendetes Teakholz / Teak recyclé

# FINITURE MANUALI

HAND FINISHINGS / HANDGEFERTIGTE AUSFÜHRUNGEN / FINITIONS À LA MAIN



**CORTEN**  
Corten



**VERDERAME**  
verdigris / grüspan / verdigris



**BRUNITO**  
Burnished



**BRONZATO**  
Bronze

# VERNICIATURE

LACQUERINGS / LACKIERUNGEN / PEINTURES

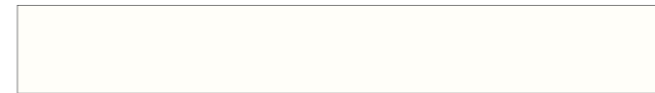

**BIANCO**  
white / weiß / blanc



**AVORIO**  
ivory / elfenbein / ivoire



**ROSSO MOSTO**  
must-red / mostrot / moût-rouge



**ANTRACITE**  
anthracite / anthrazit / anthracite



**NERO**  
black / schwarz / noir



**VERNICIATO CORTEN**  
corten powder laquered / Cortenfarbe pulverlackiert / verni à poudre corten

# METALLO

METAL / METALL / MÉTAL



**ALLUMINIO**  
Aluminium



**ALLUMINIO SATINATO**  
Aluminium

# PELLI E TESSUTI

LEATHERS AND FABRICS / LEDER UND STOFFE / CUIRS ET TISSUS



**PELLE BIANCA**  
white leather / weißes Leder / cuir blanc



**PELLE ROSSA**  
red leather / rotes Leder / cuir rouge



**PELLE NERA**  
black leather / schwarzes Leder / cuir noir



**PELLE ANTICATA TESTA DI MORO**  
antiqued dark-brown leather / antikisiertes dunkelbraunes Leder / Cuir vielli brun



**LINO BIANCO**  
white leinen / weißes Leinen / lin blanc



**LINO TORTORA**  
turtledove colour leinen / Leinen in Taupefarbe / lin couleur taupe



**LINO CACAO**  
cacao colour leinen / Leinen in Kakaofarbe / lin couleur cacao



**TESSUTO ARDESIA**  
slate colour fabric / Stoff in Schiefergrauerfarbe / tissu couleur ardoise



**TESSUTO AMETISTA**  
amethyst colour fabric / Stoff in Amethystfarbe / tissu couleur améthyste

elitetobe.it

COORDINAMENTO

Luciano Marson

GRAFICA

Tamara Pizzol

FOTO

Marco Auber

Contratti Company

VISUAL

Annalisa Berardi

UFFICIO STAMPA

MeTe

Ufficio Stampa  
& Comunicazione

STAMPA

..Grafiche Antiga

**elite,TO BE** srl

Viale Trento, 59 - 33077 Sacile (PN) - Italy - Tel. +39 0434 1758035 - Fax: +39 0434 781858 - info@elitetobe.it - www.elitetobe.it

elite,TO BE srl

Viale Trento, 59 - 33077 Sacile (PN) - Italy - Tel. +39 0434 1758035 - Fax: +39 0434 781858 - info@elitetobe.it - www.elitetobe.it